



压力表选型样本

PRESSURE GAUGE
PRODUCT SELECTION CATALOGUE

安徽天康(集团)股份有限公司
ANHUI TIANKANG(GROUP) SHARES CO.,LTD

INNOVATION MAKES EXCELLENT

有 | 跨 | 越 | 才 | 有 | 卓 | 越



ABOUT US

关于我们

长江宛如一条巨龙奔腾不息，在长江之滨的天长市有这样一颗璀璨的明珠——安徽天康（集团）股份有限公司，在经历了岁月的历练与洗礼后愈发闪耀夺目。

安徽天康（集团）股份有限公司创建于1974年，总部位于“长三角”经济圈核心区——天长市，是中国民营企业制造业500强企业、中国电子信息百强企业、国家级守合同重信用企业、国家高新技术企业、安徽省依法纳税先进企业、银行资信AAA级企业、中国仪表行业十强企业、中国电线电缆十强企业、安徽省重点骨干企业、“全国五一劳动奖状”获得者等荣誉。

天康集团历经四十年的蓬勃发展，已形成集仪器仪表、光电缆、医疗卫生、锂电池等跨行业、多元化的集团公司，下属子公司达二十余家。旗下产品凭借良好的质量与服务，被广泛应用于石油、电力、化工、通讯、卫生、新能源汽车及储能等行业和领域。

作为皖东经济最具活力与贡献的骨干企业之一，天康集团以“追求卓越，缔造满意”为目标，依托一流的产品、一流的管理、一流的服务，不仅在国内市场中赢得了广泛赞誉；在国际市场中，天康产品远销欧洲、非洲、亚洲等46个国家和地区。

天康集团在发展中逐步形成了独特的品牌文化及着眼全球的经营布局，全力塑造“高科技、高品质、国际化”的品牌形象。始终秉承“有跨越才有卓越”的天康精神，在创建和谐企业的基础上，引进国际先进的构架与模式，组织企业的生产经营管理体系。在积极参与国际化竞争的基础上，不断把握市场发展脉搏，寻求经济战略联盟，与全球伙伴共同发展与进步。如今天康人将全新的投入化为无私的奉献，与世界共同发展，与人类一起进步。

1974

成立于1974年

多项行业第一



Yangtze River like a dragon Pentium, there is such a shining pearl - Anhui Tiangkang (Group) Co., Ltd. in Tianchang City in the Yangtze River foreshore, in after years of experience and baptism increasingly shining brightly.

Anhui Tiangkang (Group) Co., Ltd. created in 1974, the headquarters is located in the "Yangtze River Delta" economic circle core area - Tianchang City, is China's private enterprises in the manufacturing industry 500 strong enterprises, China's electronic information hundred enterprises, state-level keep contract re credit enterprise, national new and high technology enterprise, Anhui Province tax law advanced enterprises, bank credit AAA level enterprise, China instrument industry ten strong enterprises, top ten enterprises in the Chinese wire and cable, Anhui province key enterprises, "national labor certificate" get "and other honorary.

After forty years of vigorous development, the group has formed a set of instruments, optical cable, medical and health, lithium batteries, such as cross industry, diversified group companies, subsidiaries of more than twenty. Products with good quality and service, is widely used in oil, electricity, chemicals, communications, health, new energy vehicles and energy storage and other industries and areas.

As one of the backbone enterprises in Anhui east economy the most vitality and contribution, tecon group to "the pursuit of excellence, creating satisfaction" as the goal, relying on the first-class products, first-class management, first-class service, not only in the domestic market won wide acclaim; in the international market, the day Kang products are exported to 46 countries and regions, including Europe, Africa, and Asia.

Tecan group in the developing gradually formed a unique brand culture and focus on global business department bureau, spare no effort to shape the brand image of "high-tech, high-quality, internationalization". Always adhering to the "excellence," the spirit of Tiangkang across only, to create the basis for a harmonious enterprise, the introduction of international advanced framework and patterns, organization of production management system. Actively participate in the international competition, and continue to grasp the pulse of the market development, to seek economic and strategic alliances, and global partners to develop and progress. Such as today, the people will be a new investment into the selfless dedication, and the common development of the world, together with the progress of mankind.

目 录

CONTENTS

Y系列一般压力表 General pressure gauge of Y series.....	01
YB系列全不锈钢压力表 YB Series Stainless Steel pressure gauge.....	04
YN系列耐震压力表 Vibration proof pressure gauge of YN series.....	06
YM系列隔膜压力表 YM Series Diaphragm pressure gauge.....	09
卫生型系列隔膜压力表 Sanitary Diaphragm Pressure Gauges.....	12
YE系列膜盒压力表 Diaphragm capsule pressure gauge of YE series.....	13
YP系列膜片压力表 Diaphragm pressure gauge of YP series.....	15
YTQ安全系列压力表 YTQ Safety pattern pressure gauges.....	17
专用压力表 Special pressure gauge.....	18
Φ40(50)表盘力表 Diameter pressure gauge of small outer.....	20
Φ200,250表盘压力表 Pressure gauge with large outer diameter.....	22
一般电接点压力表 Pressure gauge of general electric contacting point.....	24
不锈钢耐震电接点压力表 Stainless steel vibration-proof pressure gauge with electric contacting point.....	26
氨专用电接点压力表 Specialized electric contacting point pressure gauge for Ammonia.....	28
微压膜片电接点压力表 Electric contacting point pressure gauge of micro pressure diagram.....	30
YT系列防爆电接点压力表 Explosion-proof electric contacting point pressure gauge of YT series.....	32
精密压力表 Precision pressure gauge.....	35
YTZ电阻远传压力表 YTZ resistance transmission pressure gauge.....	38
YCA系列双膜片高静压差压表 YCA Series Double-diaphragm High Static Pressure Differential Pressure Gauge.....	40
化学密封 Chemical seal.....	45
附件 Accessory.....	48

Y系列一般压力表

General pressure gauge of Y series

压力表工作原理

弹簧管敏感元件是弯成圆形，积面积椭圆形的管道。测量介质的压力作用在弹簧管内侧，这样弹簧管椭圆截面会趋于圆形截面。其变形的大小取决于测量介质的压力大小。弹簧管变形通过机芯间接地由指针显示测量介质的压力。“C”型弹簧管可用于测量大约60bar的压力，对于更高的压力，弹簧管采用多重线圈或同一水平面的螺旋状线圈。

一般压力表适用于测量无爆炸，不结晶、不凝固及对铜合金不起腐蚀作用的液体或气体等介质的压力。仪表的测量系统由接头、弹簧管和传动机构组成。通过指针指示仪表读数。外径60、100、150一般压力表有径向直接安装、径向向后带边凸装、径向前带边嵌装、轴向直接安装、轴向向后带边凸装和轴向前边嵌装六中安装型号可供选择。

Working principle of pressure gauge

The sensitive element of the spring tube is made of phosphor bronze alloy material "C" type. The pressure of the measured medium inside the tube in spring, so spring pipe section elliptical cross section tends to circular cross section. The size of the deformation depends on the pressure of the medium. The deformation of the spring tube is indirectly by the movement of the core by a pointer to display the pressure of the measuring medium. "C" type spring tube can be used to measure the pressure of about 60bar, for higher pressure, the spring tube using multiple coils or the same level of spiral coil.

The general pressure gauge is suitable for measuring the pressure of a liquid or gas and other material with no explosion, crystal, solidifying and no corrosion to the copper alloy. The measuring system of the instrument is composed of a joint, spring tube and a transmission mechanism and the value of the meter is displayed by the pointer. For the 60, 100, 150 general pressure gauge, there are 6 models optional which are respectively are bottom mounting, bottom mounting with back flange, bottom mounting with front flange, back mounting, bottom mounting with back flange and bottom panel mounting with front flange.



选型注意事项

用户必须依据现场的工作环境、刻度范围和性能来选择合适的压力表。

根据各种表的应用范围来选择压力的类型。量程应选择理想操作压力在阴影范围内。仪表的压力部分一般使用至压力测量范围的3/4。

压力仪表的安装应注意如下情况：

- ▶ 远离热源、震动及安装便于观察；
- ▶ 压力接口连接需密封；
- ▶ 如果必要也可使用毛细管连接安装；
- ▶ 防护等级：IP66；
- ▶ 执行标准：GB/T 1226-2010。

主要技术指标

测量范围、测量精度

型号 Model	Y-60 Y-60-Z Y-60T Y-60ZT	Y-100 Y-100T Y-100ZT	Y-150 Y-150T Y-150ZT
精度等级 Grade of precision	2.5	1.0、1.6	
测量范围MPa Grade of precision	0~0.1, 0.16, 0.25, 0.4, 0.6, 1, 1.6, 2.5, 4, 6		
	0~10, 16, 25, 40	0~10, 16, 25, 40, 60, 100, 160, 250	
	-0.1~-0.06, 0.15, 0.3, 0.5, 0.9, 1.5, 2, 4		

The environmental conditions for usage: -40~70°C and the relative humidity is not more than 85%
Temperature effect: when the temperature is within 20±5°C, it is not more than 0.4%/10°C

外形尺寸

Outline dimension

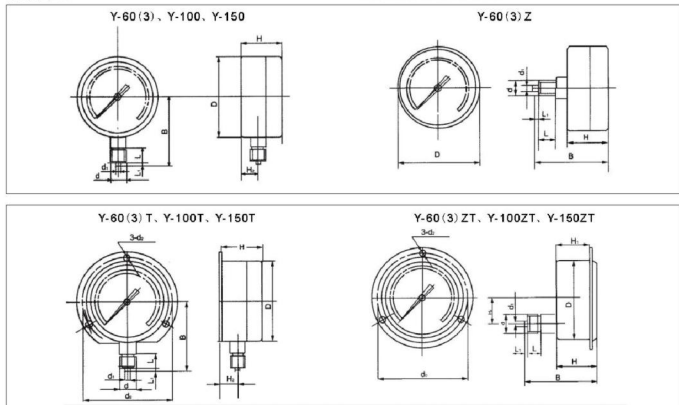

Selection attention

The users must select the appropriate pressure gauge according to the working environment, the scale range and the performance required.

Users may select the type of pressure according to the scope of application. Range should selected the ideal operating pressure which must be in the shadow range. The pressure scope used for the gauge is generally used within 3/4 of the total range of pressure.

The installation of pressure gauges should be noted as follows:

- ▶ It should be away from heat heat source, vibration and it must be easy for observation when installation;
- ▶ Pressure port connection should be sealed;
- ▶ If necessary, the capillary can also be used for installation.
- ▶ Protection level: IP66
- ▶ Execution standard: GB/T1226-2010

Main technical indexes

Measuring range and measuring precision

Model	D	d		L	d0	B	H	d2	H1	H2	L1	
Y-60	φ60	M14×1.5	φ5	14	-	55	30	-	-	13	2.5	
Y-60Z					-	52	30	-	-	0		
Y-60ZT					-	55	30	φ4.5	-	13		
Y-60T					-	52	30	φ4.5	25	0		
Y-100					-	90	44	-	-	18		
Y-100T	φ100	M20×1.5	φ6	20	118	90	44	φ5.5	-	18		
Y-100ZT					-	90	44	φ5.5	36	32		
Y-150					-	115	47	-	-	18		
Y-150T					φ150	-	115	47	φ5.5	-		18
Y-150ZT						165	80	47	φ5.5	36		55

Y系列一般压力表产品选型

Y series product selection of general pressure gauge

一般压力表 Y- General pressure gauge Y-						
表盘直径 Diameter of the gauge dis						
φ60	60					
φ100	100					
φ150	150					
安装方式 Installation method						
径向直接安装	Bottom mounting					
径向带后边凸装	Bottom mounting with back flange	无代码	No coding			
径向带前边嵌装	Bottom mounting with front flange					
轴向直接安装	Back mounting		T			
轴向带后边凸装	Back mounting with back flange		Z			
轴向带前边嵌装	Back mounting with front flange		ZT			
			ZQ			
过程连接 Process connection						
M14×1.5	M14×1.5					
M20×1.5	M20×1.5					
G1/2	G1/2					
1/2" NPT	1/2" NPT					
其他(注明)	其他(注明)					
Others(note)	Others(note)					
接液材质 Liquid material						
铜	Copper				Cu	
精度等级 Precision grade						
1.0					1.0	
1.6					1.6	
2.5					2.5	
4.0					4.0	
附件可选 Optional accessories						
阻尼器	Damper					ZN
散热器	Radiator					SR
过压保护器	Overvoltage protection device					OP
冷凝管	Siphon tube					SP
其他	Others					文字注明
						Text description

注: 1. 安装方式中: φ60常规的是轴向同心式, φ100、φ150的为轴向偏心式。若要其他安装方式的, 请咨询销售工程师并在订货时注明。
 Note: 1. installation methods: for the φ60, the conventional type is the axial concentric one, for the φ100, φ15, it is the axial eccentric type. If other installation is required, please consult the sales engineer and specify the demand when ordering.

YB系列全不锈钢压力表

YB Series Stainless Steel pressure gauge

工作原理

仪表由导压系统(包括接头、弹簧管等)、齿轮传动机构、指示装置和外壳组成。全部零件均采用不锈钢材料制成。当弹簧管在被测介质的压力作用下,其管端产生相应的弹性变形,经齿轮传动机构放大,由指示装置将被测压力值在表盘上指示出来。仪表外壳为密封型结构,能有效地保护内部件免受环境影响和污秽的侵入。同时通过对表壳内充油,能够抗被测介质压力的脉动和工作环境剧烈震动的影响,兼顾了耐腐蚀及抗震性能。

全不锈钢压力表广泛应用于石油、化工、冶金、轻工、化纤等工业部门。可测量腐蚀性较强介质的压力,并能在有剧烈振动和工作环境较恶劣的场合使用。

仪表零件均采用不锈钢材料制成。整机结构设计新颖,工艺精良。仪表具有较高的测量精确度和持久的稳定性,使用适应性强。是国内用户对引进国外先进技术装备中同类型仪表实现国产化的理想配套产品。

Working principle

The instrument consists of pressure guiding system (including joint, spring tube, etc.), gear drive system, indication device and shell. All the components are made of stainless steel. When the spring tube is under the pressure of the measured medium, corresponding elastic deformation will be produced on the pipe end, which is amplified by the gear drive mechanism and the measured pressure value is indicated by the indication device on the dial. The instrument shell is sealing structure which can protect effectively the internal parts from environmental influence and intrusion of filth. Meanwhile, filling oil into the shell is able to resist the pulsation of the measured medium pressure and influence of abrupt vibration of working environment, considering both the resistance to the corrosion and shock. Full stainless steel pressure gauges are widely applied to industries like petroleum, chemistry, metallurgy, chemical fiber, etc. They are able to measure the pressure of medium which is strongly corrosive and they can be applied in areas with strong vibration and harsh working environment.

The instrument components are all made of stainless steel. The structure of the whole machine is novel in design and fine in process. The instrument has high measurement accuracy, lasting stability and strong operation adaptability. It is ideal supporting product to realize localization of similar type of instrument in imported foreign advanced technology equipment.

主要技术指标

标度范围、精确度等级

Main technical indexes

Scale range and accuracy class

型号 Model	标度范围MPa Scale Range Mpa	精确度等级 Accuracy Class
Y-60B Y-63B	0-0.6, 1, 1.6, 2.5, 4, 6, 10, 16, 25, 40, 60, -0.1-0.5, 0.9, 1.5, 2.4	2.5, 4.0
Y-100B Y-150B	0-0.1, 0.16, 0.25, 0.4, 0.6, 1, 1.6, 2.5, 4, 6, 10, 16, 25, 40, 60, 100, 160, 250 -0.1-0, 0.06, 0.15, 0.3, 0.5, 0.9, 1.5, 2.4	1.0, 1.6, 2.5

使用环境温度: -40~70°C;

温度影响: 不大于0.4%10°C(使用温度偏离20±5°C);

抗工作环境振动: V-H-3;

外壳防护等级: IP66,

Ambient temperature for operation: -40~70°C

Temperature influence: no more than 0.4%10°C (the operation temperature deviates by 20±5°C)

Anti-vibration in the working environment: V-H-3

Shell Protection Class: IP66

零件 Part	材料牌号 Material grade	
名称 Name	YB-60	YB-100, YB-150
接头 Joint	0Cr18Ni9 (304)	0Cr17Ni12Mo2 (316)
弹簧管 Spring tube	12Cr18Ni9 (321)	0Cr17Ni12Mo2 (316)
外壳 Shell	12Cr18Ni9 (321)	

外形尺寸

Outline dimension

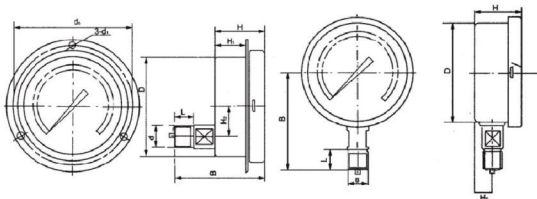

型号 Model	D	B	d	L	H	H2
YB-60	φ60	55	M14×1.5、1/4" (NPT)	14	35	13
YB-100	φ100	90	M20×1.5 G、1/2"		44	18
YB-150	φ150	120	1/2"NPT	20	44	18

YB系列全不锈钢压力表产品选型

The selection of stainless steel pressure gauge

全不锈钢压力表YB- Whole stainless steel pressure gauge YB-					
表盘直径 Diameter of the gauge dis					
φ60	60				
φ100	100				
φ150	150				
安装方式 Installation method					
径向直接安装	Bottom mounting				
径向带后边凸装	Bottom mounting with back flange				
径向带前边凸装	Bottom mounting with front flange	无代码	No coding		
轴向直接安装	Back mounting			T	
轴向带后边凸装	Back mounting with back flange			Z	
轴向带前边凸装	Back mounting with front flange			ZT	
				ZQ	
过程连接 Process connection					
M14×1.5			M14×1.5		
M20×1.5			M20×1.5		
G1/2			G1/2		
1/2"NPT			1/2"NPT		
其他(注明)			其他(注明)		
Others(note)			Others(note)		
接液材质 Liquid material					
304SS				304	
316SS				316	
精度等级 Precision grade					
1.0				1.0	
1.6				1.6	
2.5				2.5	
4.0				4.0	
附件可选 Optional accessories					
阻尼器	Damper				ZN
散热器	Radiator				SR
过压保护器	Overvoltage protection device				OP
冷凝管	Siphon tube				SP
其他	Others				文字注明
					Text description

YN系列耐震压力表

Vibration proof pressure gauge of YN series



应用

耐震压力表主要用于冶金、电力、石油、化工、轻工、机械等工业部门的压力检测。压力表依靠内部充灌阻尼油和配套缓冲装置等措施，具有良好的耐震性能。适用于被测介质的压力有强烈脉冲变化或压力冲击和在生产工艺中经常突然卸荷的场合；以及环境震动较大的场所。仪表能测量气体、液体脉动压力的平均值，以克服介质强烈脉冲及环境震动对仪表带来的损害，确保读数的准确性。

不锈钢耐震压力表的外壳用不锈钢材料制成(简称半钢)，可在有腐蚀性、震动较大的恶劣环境中使用。

本仪表的观察窗选用高强度的工程塑料或安全玻璃制成。仪表指示清晰，使用安全可靠。

Application

The shock-proof pressure gauge is mainly used to check the pressure for industrial sectors like metallurgy, electric power, petroleum, chemical industry, light industry and machinery. The pressure gauge is provided with measures like filling damping oil inside and with damping device, so it has good shock-proof performance. It is applicable to fields where the pressure of the measured medium experiences strong pulse change or pressure impact and when there is often sudden unloading during the production process and sites where the environmental vibration is large. The gauge is able to measure the average value of the gas and liquid pulsation pressure to overcome the damage to the gauge due to strong medium pulse and environmental vibration so as to ensure the accuracy of the reading.

The shell of stainless shock-proof pressure gauge is made from stainless steel (simply called semi-steel) and it is able to be used in harsh environment with corrosivity and large vibration. The observation window of this instrument is made from engineering plastic with high strength. The instrument has clear indication, safe and reliable operation.

主要技术指标

型号、结构型式、标度范围及精确度等级

Main technical index

Model, structural type, scale range and accuracy level

型号 Mode	结构型式 Structure Type	标度范围MPa Scale Range Mpa	精确度等级 Accuracy Class
YN-60	径向 Radial	0~0.1; 0~0.16;0~0.25;0~0.4; 0~0.6;0~1.0~1.6;0~2.5;0~4; 0~6.0~10.0~16.0~25	2.5,4.0
YN-60ZT	轴向带边 Axial with side		
YN-100	径向 Radial	0~0.1; 0~0.16;0~0.25;0~0.4; 0~0.6;0~1.0~1.6;0~2.5;0~4; 0~6.0~10.0~16.0~25;0~40.0~60.0~100.0~160.0~250	1.0,1.6,2.5
YN-100ZT	轴向带边 Axial with side		
YN-150	径向 Radial		
YN-150ZT	轴向带边 Axial with side		
YN-150	径向 Radial	0~0.1; 0~0.16;0~0.25;0~0.4; 0~0.6;0~1.0~1.6;0~2.5;0~4; 0~6.0~10.0~16.0~25;0~40; 0~60.0~100.0~160.0~250	

1. 使用环境温度: 5~55°C(表壳内充甘油) -40~70°C(表壳内充硅油)

2. 抗工作环境振动等级: V-H-4,V-H-5.

1. Ambient temperature for operation: 5~55°C (glycerine filled in the shell), -40~70°C (silicon oil filled in the shell).

2. Anti-vibration class in the working environment: V-H-4.

标度范围、精确度等级

Scale range and accuracy class

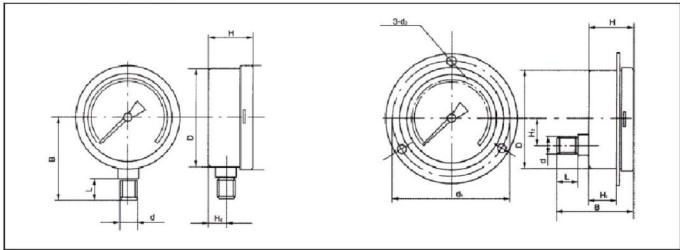

型号 Model	D	H	H2	B	d2	d0	d	L	H1
YN-60	φ60	32	13	55	-	-	M14×1.5	14	-
YN-60ZT		32	0	65	4.5	76			22
YBN-60		32	13	55	-	-			-
YN-100	φ100	44	18	90	-	-	M20×1.5	20	-
YN-100ZT		44	30	90	5.5	118			27
YBN-100		44	18	90	-	-			-
YN-150	φ150	44	18	120	-	-	M20×1.5	20	-
YN-150ZT		44	55	95	5.5	165			27
YBN-150		44	18	120	-	-			-

填充液指标

Filling index

填充液名称 Name of filling liquid	折射率(25°C) Refractive index	闪点(°C) Flashing point	膨胀率 25~150°C (cc/cc/°C) Flashing point	比热 25°C (cal/g·°C) Specific heat	流动点(°C) Pour point
硅油 (50cs) Silicone oil (50cs)	1.402	300	0.00096	0.36	-50
硅油 (100cs) Silicone oil (100cs)	1.403	300	0.00095	0.35	-50
硅油 (500cs) Silicone oil (500cs)	1.403	300	0.00095	0.35	-50
甘油 (99.5%) Glycerol	1.474	160	0.000615	0.602	20

YB系列耐震压力表产品选型

Products model selection for YB series
vibration proof pressure gauge

压力表Y- Pressure gauge Y-									
壳体+元件材质 Shell + element material									
碳钢+铜 Carbon steel + copper	无代码 No coding								
不锈钢+不锈钢 Stainless steel + stainless steel	B								
压力表类别 Pressure gauge category									
耐震 Vibration proof	N								
连接符号 Connection symbol									
	-								
表盘直径 Diameter of the gauge disc									
φ60	60								
φ100	100								
φ150	150								
其他	Other								
安装方式 Installation method									
径向直接安装 Bottom mounting									
径向带后边凸装 Bottom mounting with back flange	无代码 No coding								
径向带前边板装 Bottom mounting with front flange	T								
轴向直接安装 Back mounting	Q								
轴向带后边凸装 Back mounting with back flange	Z								
轴向带前边板装 Back mounting with front flange	ZT								
	ZQ								
过程连接 Process connection									
M14×1.5	M14×1.5								
M20×1.5	M20×1.5								
G1/2G1/2	G1/2G1/2								
1/2"NPT	1/2"NPT								
其他(注明)	Others(note)								
接液材质 Liquid material									
铜 Copper									
304SS	Cu								
316SS	304								
其他	316								
	Other								
精度等级 Precision grade									
1.0 Grade	1.0								
1.6 Grade	1.6								
2.5 Grade	2.5								
其他	Others(note)								
表壳填充液 Filling liquid for the gauge shell									
硅油(低粘度) Silicone oil (low viscosity)									H
硅油(高粘度) Silicone oil (high viscosity)									I
甘油 Glycerol									J
附件可选 Optional accessories									
阻尼器 Damper									ZN
散热器 Radiator									SR
过压保护装置 Overvoltage protection device									OP
冷凝管 Siphon tube									SP
其他 Others									文字注明 Text description

YM系列隔膜压力表

YM Series Diaphragm pressure gauge



工作原理

隔膜压力表由各种通用型压力仪表和不同结构的隔膜隔离器组成一个封闭系统，内充密封液。当被测介质的压力作用于隔膜时，则隔膜产生变形，压缩封闭系统中的密封液。由于密封液的固有性质，使压力仪表中的弹性元件产生相应的弹性变形—位移，经指示装置显示压力值。当隔膜的刚度足够小时，则压力仪表指示的压力就近于被测介质的压力值。

为了扩大各种通用型压力仪表的使用范围，能适用于测量强腐蚀、高温、高粘度、易结晶、易凝固和有固体浮游物介质的压力，以及对某些测量介质不能直接进入通用型压力仪表内和便于清洗防止沉淀物积聚的场合的压力检测时，必须采用由隔膜隔离器与通用型压力仪表组成一个系统的隔膜表。

隔膜表主要用于石油、化工、制药、食品、轻纺等工业部门生产过程中的压力检测。

隔膜表的温度特性

尤其对于带软连接管的隔膜表，由于隔膜受压部与通用型压力表安装位置不在同一水平面上，会产生液位差的影响量 ΔP 。在精确测量时应更注意。

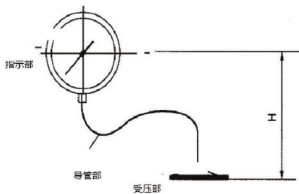

$\Delta P = d \cdot h$ d-密封液的比重; H-液位差

$\Delta P = d \cdot h$ d-specific weight of the sealing liquid; H-liquid level difference

Working principle

Diaphragm pressure gauge forms one closes system by different types of general pressure gauges and different structures of diaphragm isolators, filled with sealing liquid. When the pressure of the measured medium acts on the diaphragm, the diaphragm will produce deformation and compress the sealing liquid. Due to the inherent nature of the sealing liquid, the elastic element in the pressure gauge produces relevant elastic deformation—displacement, and the pressure value is displayed through indication device. When the rigidity of the diaphragm is small enough, the pressure indicated by the pressure gauge is close to the pressure value of the measured medium.

In order to expand the operation range of the general pressure gauges, making them suitable to measure the pressure of medium of strong corrosion, high temperature, high viscosity, easy to crystallize, solidify and with solid suspended matters, and when some measurement medium can not enter directly the general pressure gauge and it is easy to clean and prevent the sediment from gathering, one systematic diaphragm meter consisting of diaphragm isolator and general pressure gauge must be adopted.

The diaphragm meters are mainly applied to pressure check during production of industrial departments like petroleum, chemistry, pharmacy, food, lighttextile.

Temperature characteristics of diaphragm pressure gauge

Particularly for the diaphragm meter with soft connection pipe, since the installation position of the pressed part of the diaphragm and the general pressure gauge is not at the same horizontal plane, the influence amount ΔP of the liquid level difference will be produced, which shall be noticed during accurate measuring.

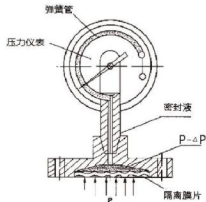

主要技术指标

测量范围、测量精度

表盘直径 Dial diameter	60, 100, 150
精度等级 Grade of precision	1.0, 1.6, 2.5
测量范围 (MPa) Grade of precision	0~0.1, 0.16, 0.25, 0.4, 0.6, 1, 1.6, 2.5, 4, 6 0~10, 16, 25, 40, 60, 100, 160, 250 -0.1~0.06, 0.15, 0.3, 0.5, 0.9, 1.5, 2.4

Main technical indexes

Measuring range and measuring precision

法兰的选择

现根据GB(国标)、HGJ(化工部)、DIN(德标)、JIS(日标)、ANSI(美标)等法兰标准以及国内实际使用情况编制成常用法兰系列标准,供用户选用。也可以接受用户其他规格的特殊订货。

Selection of flange

Normal flange series standards are prepared according to the flange standards like GB (Chinese), HGJ (ministry of chemical industry), JIS (Japanese), ANSI (American) and actual operation situation in China. The customer can select the flange. Special order of other specifications from the customers are also accepted.

密封液的选择

为保证隔膜表使用可靠性和安全性,应根据不同用途选择合适的密封液。

Selection of sealing liquid

In order to ensure the reliability and safety of the use of diaphragm meter, proper sealing liquid shall be selected depending on different use.

密封液 Sealing Liquid	受压部温度范围 Temperature Range of the Pressed Part	比重g/cm3 Specific Weight g/cm3	体膨胀系数1/℃ Expansion Coefficient of the Body 1/℃	用途 Use
高粘度硅油 High-viscosity silicon oil	-10~200℃	1.07	0.95x10 ⁻³	高温用 High temperature use
低粘度硅油 Low-viscosity silicon oil	-30~100℃	0.94	1.08x10 ⁻³	一般用 General use
甘油水溶液 Glycerin water solution	-5~100℃	1.27	0.61x10 ⁻³	食品用 For food
植物油 Vegetable oil	-5~100℃	0.93	1.03x10 ⁻³	食品用 For food
氟油 Fluorine oil	-30~150℃	1.93	0.75x10 ⁻³	氢、氧 Hydrogen, oxygen

隔离膜片材质

Isolated diaphragm material

类型 Type	材质 Material
隔离膜片 Isolated diaphragm	316LSS、316LSS+PTFE, 哈氏合金HC-276, 钽Ta, 钛Ti, 蒙乃尔Monel400

关于隔离膜片部分耐腐蚀材料的选择

Selection of corrosion resistant materials for diaphragm plate of the isolated body

腐蚀性介质 Corroding Medium	腐蚀材料 Medium of erosion				
	316L SS	PTFE	Hastelloy, c-276	Ta	Monel 400
硫酸 Sulphuric acid	▲	■	■	★	■
硝酸 Nitric acid	■	■	■	★	×
盐酸 Hydrochloric acid	×	■	■	★	×
磷酸 Phosphoric acid	■	■	■	★	■
醋酸 Acetic acid	■	■	★	★	■
烧碱 Caustic soda	★	■	★	▲	★
纯碱 Medium of erosion	★	■	■	★	★
小苏打 Sodium bicarbonate	★	■	★	★	★
氯气 Chlorine gas	干: ■ 湿: × Dried: ■ Wet: ×	■	■	★	干: ■ 湿: × Dried: ■ Wet: ×
溴 Bromine	干: × 湿: ▲ Dried: × Wet: ▲	■	★	★	干: × 湿: ▲ Dried: × Wet: ▲
氨水 Ammonia hydroxide	■	■	★	×	■
海水 Seawater	■	■	★	★	★

符号说明 Sign description: ★ 最佳 Optimum ▲ 有条件使用 Used in some conditions ■ 可以使用 Usable × 不可以使用 Unusable

YM系列隔膜压力表选型

YM Series Diaphragm pressure gauge

压力表YM Pressure gauge YM									
隔膜形式 Diaphragm type									
隔膜法兰 Diaphragm thread	F								
隔膜螺纹 Diaphragm thread	L								
压力表类别 Pressure gauge category									
不耐震 Pressure gauge category	无 (可省略) Null(omitted)								
耐震 Vibration proof	N								
连接符号 Connection symbol									
表盘直径 Diameter of the gauge disc									
φ60						60			
φ100						100			
φ150						150			
与隔膜体安装方式 Installation mode with the diaphragm									
径向直接安装 Bottom mounting							无代码 No coding		
轴向直接安装 Back mounting							Z		
过程连接 Process connection									
法兰连接 Flange connection							文字说明 Text description		
螺纹连接 Thread connection							文字说明 Text description		
膜片材质 Diaphragm material									
316L SS									
H.C合金 H.C alloy							316		
Ta							H.C		
Ti							Ta		
蒙乃尔 Monel							Ti		
其他 Others							蒙乃尔 Monel		
							文字说明 Text description		
精度等级 Precision grade									
1.0 Grade								1.0	
1.6 Grade								1.6	
2.5 Grade								2.5	
其他 Others								Others(note)	
表壳填充液 Filling liquid for the gauge shell									
硅油 (低粘度) Silicone oil (low viscosity)									H
硅油 (高粘度) Silicone oil (high viscosity)									I
甘油 Glycerol									J
附件可选 Optional accessories									
阻尼器 Damper									ZN
散热器 Radiator									SR
过压保护器 Overvoltage protection device									OP
冷凝管 Siphon tube									SP
其他 Others									文字注明 Text description

卫生型系列隔膜压力表

Sanitary Diaphragm Pressure Gauges

产品简介

介质不与仪表测量系统相接触，隔膜密封不会产生死角或无法排空的区域，适用于卫生级系统。

主要技术指标

- YB-100/MC、YB-150/MC仪表外径
- 外壳、内机全不锈钢材质
- 精度：1%，1.6%



YB-100/MC

管线螺纹连接

可提供欧洲及各类加工标准
注：详细标准尺寸请在订货时进行确认

Made to Europe standard and various standards
DIN:SMS,IFD:APV-RJT

Note:When ordering,please specify detailed standard and dimensions.



YTP-100HF7

Product introduction

Media does not directly contact instrument's measuring system, diaphragm seal does not raise a dead corner or area where residue may be left, universally used for sanitary applications.

Main technical index

- YB-100/MC、YB-150/MC Outside diameter
- Stainless steel case and internals
- Accuracy: 1%; 1.6%

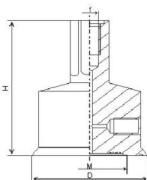

DN	D(mm)	H(mm)	f	M
1"	42	48	3/8-24UNF2B	19
1.5"	50.5	48	3/8-24UNF2B	30
2"	64	48	3/8-24UNF2B	38
2.5"	77.5	48	3/8-24UNF2B	47

Threaded process connection

DIN 11851

DN	DAMPO SCALA RANGE	H	h	g	m	f (DIN405)
25	0/9-40BAR	44	21	62	20.5	R052x1/8
32	0/4-40BAR	46	21	70	29	R059x1/8
40	0/2.5-40BAR	46	21	78	36	R065x1/8
50	0/1.6-40BAR	47	22	82	50	R078x1/8

SMS 681

DN	DAMPO SCALA RANGE	H	h	g	m	f (DIN405)
1"X	0/4-40BAR	49.5	26	74	29	R060x1/8
2"	0/2.5-40BAR	50.5	26	84	36	R070x1/8

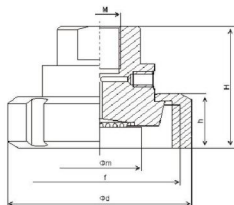

YE系列膜盒压力表

Diaphragm capsule pressure gauge of YE series

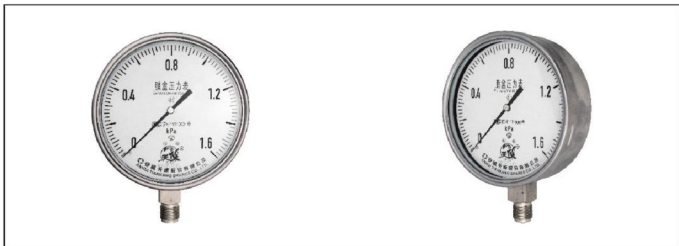

工作原理

膜盒压力表采用膜盒作为测量微小压力的敏感元件。测量对铜合金不起腐蚀性作用、无爆炸危险气体的微压和负压，广泛应用于锅炉通风、气体管道、燃烧装置及其它类似设备上。

Working principle

Diaphragm capsule pressure gauge uses the diaphragm capsule as the sensitive element for measuring micro pressure. It is used to measure the micro pressure and negative pressure which can not exert effectiveness on the corrosion, non explosive dangerous gas. It is widely used in the ventilation, gas pipeline, combustion device and other similar equipment.

主要技术指标

型号、结构型式、标度范围及精确度等级

Main technical index

Mode, structural type, scale range and accuracy level

型号 Mode	标度范围KPa Scale Range Kpa			精确度等级 Accuracy Class
	正压 Positive pressure	负压 Negative pressure	正负压 Positive and negative pressure	
YE-60 YE-100 YE-150 YEB-60 YEB-100 YEB-150	0~0.2	-0.2~0	-0.1~+0.1	2.5
	0~1.6	-1.6~0	-0.8~+0.8	
	0~2.5	2.5~0	-1.2~+1.2	
	0~4	-4~0	-2~+2	
	0~6	-6~0	-3~+3	
	0~10	-10~0	-5~+5	
	0~16	-16~0	-8~+8	
	0~25	-25~0	-12~+12	
0~40	-40~0	-20~+20		

YE系列隔膜压力表选型

Diaphragm capsule pressure gauge of YE series

压力表YE Pressure gauge YE								
壳体+元件材质 Shell + element material								
碳钢+铜 Carbon steel + copper	无代码 No coding							
不锈钢+不锈钢 Stainless steel + stainless steel	B							
连接符号 Connection symbol		-						
表盘直径 Diameter of the gauge disc								
φ60						60		
φ100						100		
φ150 (160)						150 (160)		
安装方式 Installation method								
径向直接安装 Bottom mounting								
径向带后边凸装 Bottom mounting with back flange	无代码 No coding							
径向带前边凸装 Bottom mounting with front flange	T							
轴向直接安装 Back mounting	Z							
轴向带后边凸装 Back mounting with back flange	ZT							
轴向带前边凸装 Back mounting with front flange	ZQ							
过程连接 Process connection								
M14×1.5						M14×1.5		
M20×1.5						M20×1.5		
G1/2						G1/2		
1/2"NPT						1/2"NPT		
其他 Others						文字说明 Text description		
液体材质 Liquid material								
铜 Copper							Cu	
304SS							304	
316SS							316	
其他							Other	
精度等级 Precision grade								
1.0 Grade							1.0	
1.6 Grade							1.6	
2.5 Grade							2.5	
其他 Others							Others(note)	
附件可选 Optional accessories								
阻尼器 Damper							ZN	
散热器 Radiator							SR	
过压保护器 Overvoltage protection device							OP	
冷凝管 Siphon tube							SP	
其他 Others							文字注明 Text description	

YP系列膜片压力表

Diaphragm pressure gauge of YP series



结构原理

仪表由测量系统(包括接头、法兰、膜片)、传动机构、指示装置和外壳组成。仪表为密封型防護结构,能有效地保护内部机件免受环境影响和污秽侵入。

在被测介质的压力作用下,仪表的弹性元件(膜片)产生与压力大小成正比的弹性变形——位移,借助连杆经传动机构放大,由指示装置指示出被测压力值。

膜片压力表适用于测量有一定腐蚀性、粘稠介质和非结晶或非凝固的各种流体介质的压力或负压。

可根据测量介质对耐腐蚀性能的不同要求而选用不同材料的膜片。

外壳使用不锈钢材料的仪表,可在工作环境较恶劣的情况下使用。

主要技术指标

Structure principle

The instrument consists of measuring system (including joint, flange and diaphragm), drive system, indication device and shell. The instrument is the sealing type with splash-proof structure which is able to protect effectively the internal parts from environmental influence and filth intrusion.

With the pressure action of the measured medium the elastic element of the instrument (diaphragm) produces the elastic deformation directly proportionate to the pressure size--displacement, which is magnified by drive mechanism with the help of connection rod and then the

Diaphragm pressure gauge is applicable to measure the pressure or negative pressure of various kinds of fluid medium with certain corrosivity, viscous medium and amorphous or non-coagulated medium.

Diaphragm of different materials can be selected depending on the different requirements of the measurement medium for corrosion resistance performance.

The instrument whose shell is made from stainless steel can be used in harsh working environment.

Main technical index

仪表类型 Instrument type	普通型、耐震型(充油) General type, Vibration-proof type (oil)
指示直径 Indicator diameter	φ100, φ150
精度 Accuracy	1.6级、2.5级 1.6, 2.5
测量范围 Measuring range	正压 0~0.2kPa/0~4kPa至0~100kPa Positive pressure 0~0.2kPa/0~4kPa to 0~100kPa 负压 -4~0kPa/-0.2~0kPa至-100~0kPa及任何相关正负压力量程 Negative pressure -4~0kPa/-0.2~0kPa to -100~0kPa and any relevant
膜片材质 Diaphragm material	304, 316, 喷涂PTFE 304, 316, spraying PTFE
接头材质 Joint material	304, 316
外壳材质 Shell material	304
防护等级 Protection temperature	IP66
连接尺寸 Connection dimension	螺纹连接M20×1.5, 法兰连接按标准, 特殊连接需质询后在订货前注明 Common type: -40~70 vibration proof type: -20~60 °C M20×1.5 threaded connection, flange connection according to the standard, special connection to be questioned before ordering

外形尺寸

YPF-100 A/B 单位: mm

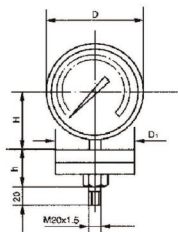

Outline size

YPF-100 B/F 单位: mm

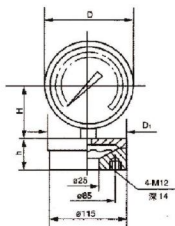

	YPF-100A	YPF-100B	YPF-100B-F	YPF-150A	YPF-150B	YPF-150B-F
D	φ100	φ110	φ110	φ150	φ160	φ160
H	66	66	66	91	91	91
h	32	32	36	32	32	36

YP系列膜片压力表选型

Type selection of diaphragm pressure gauge of YP series

膜片压力表 YP Pressure gauge YP						
耐震功能 Shock resistance function						
不防震 Pressure gauge category		无 (可省略) Null(omitted)				
防震 Vibration proof		N				
连接符号 Connection symbol		-				
表盘直径 Diameter of the gauge disc						
φ100		60				
φ150		150				
过程连接 Process connection		M20×1.5				
M20×1.5		M20×1.5				
法兰连接 Flange connection		文字说明 Text description				
其他 Others		文字说明 Text description				
膜片材质 Diaphragm material						
316L SS		316				
H.C合金 H.C alloy		H.C				
Ta		Ta				
Ti		Ti				
蒙乃尔 Monel		蒙乃尔 Monel				
316喷四氟 316 Spraying PTFE		316+PTFE				
其他 Others		文字说明 Text description				
表壳填充液 Filling liquid for the gauge shell						
硅油 (低粘度) Silicone oil (low viscosity)		H				
硅油 (高粘度) Silicone oil (high viscosity)		I				
甘油 Glycerol		J				
精度等级 Precision grade						
1.6 Grade		1.6				
2.5 Grade		2.5				
其他 Others		Others(note)				
附件可选 Optional accessories						
阻尼器 Damper		ZN				
散热器 Radiator		SR				
过压保护器 Overvoltage protection device		OP				
冷凝管 Siphon tube		SP				
其他 Others		文字注明 Text description				

YTQ安全系列压力表

YTQ Safety Pattern Pressure Gauges

不锈钢坚固型安全压力表 (YTQ-160H, YTQ-100H, YTQ-63H)

All stainless steel solid frint safety pattern gauges

- 精度: 1%, 1.6%
 - 隔板后释放装置, 不锈钢安全构造外壳
 - 接液部分材质: SUS316
 - 量程: -0.1~160MPa
 - 安全双层玻璃
 - 安装形式可选: 径向, 下轴向, 轴向嵌装
-
- Accuracy: 1%, 1.6%
 - Blow out back, stainless steel safety case design
 - Wetted part: SUS316
 - Range: -0.1~160MPa
 - Laminates safety glass
 - Mounting options: Bottom connection/back connection flush mounting.



聚丙烯外壳安全型压力表 (YTQ-4½"S)

Polypropylene case safety pattern gauges

- 精度: 1%, 1.6%
 - 量程: -0.1~160MPa
 - 内机铜合金普通型或内机不锈钢防腐型可选
 - 具有安全隔板及卸压后盖坚固的仪表外壳
-
- Accuracy: 1%, 1.6%
 - Range: -0.1~160MPa
 - Copper alloy internal standard, optional stainless steel internals corrosion-proof
 - Rugged built case with solid baffle and blow out back



YTQ(F)-4½"ZS普通(防腐)轴向
Back connection standard (corrosion-proof)



YTQ(F)-4½"普通(防腐)径向
Bottom connection standard (corrosion-proof)

专用压力表

Special pressure gauge



主要技术指标

Main technical index

名称 Name	氧气压力表 Oxygen pressure gauge			氢气压力表 Hydrogen pressure gauge			氨气压力表 Ammonia pressure gauge		
	φ60	φ100	φ150	φ60	φ100	φ150	φ60	φ100	φ150
公称直径 Nominal direct	φ60	φ100	φ150	φ60	φ100	φ150	φ60	φ100	φ150
精确度等级 Precision class	±2.5%	±1.0%	±1.6%	±2.5%	±1.6%	±1.6%	±2.5%	±1.6%	±1.6%
连接螺纹 Connection thread	M14×1.5	M20×1.5	M20×1.5M	M14×1.5	M20×1.5M	M20×1.5M	M14×1.5	M20×1.5	M20×1.5
类型 Category	径向后边 Bottom back mounting 径向前边 Bottom front mounting 轴向直接安装 Back mounting 轴向前带边安装 Back mounting with front flange 轴向前带边嵌装 Back mounting with front flange								
测量范围 Measuring range	0~0.06, 0~0.1, 0~0.16, 0~0.25, 0~0.4, 0~0.6, 0~1, 0~1.6, 0~2.5, -0.1~0, -0.1~0.06, -0.1~0.15, -0.1~0.3, -0.1~0.5, -0.1~0.9, -0.1~1.5, -0.1~2.4, 0~4, 0~6, 0~10, 0~16, 0~25, 0~40, 0~60, 0~100, 0~160, 0~250								

专用压力表选型

Selection of special pressure gauge

专用压力表Y Pressure gauge Y							
类型 Category							
氨用 Used for ammonia	A						
氧用 Used for oxygen	O						
氢气 Used for hydrogen	H						
耐震功能 Shock resistance function							
不耐震 Pressure gauge category	无 (可省略) Null(omitted)						
耐震 Vibration proof	N						
连接符号 Connection symbol							
表盘直径 Diameter of the gauge disc							
φ60				60			
φ100				100			
φ150				150			
安装方式 Installation method							
径向直接安装 Bottom mounting							
径向带后边凸装 Bottom mounting with back flange					无代码 No coding		
径向带前边嵌装 Bottom mounting with front flange					T		
轴向直接安装 Back mounting					Q		
轴向带后边凸装 Back mounting with back flange					Z		
轴向带前边嵌装 Back mounting with front flange					ZT		
					ZQ		
过程连接 Process connection							
M14×1.5				M14×1.5			
M20×1.5				M20×1.5			
G1/2				G1/2			
1/2"NPT				1/2"NPT			
其他 Others				文字说明 Text description			
精度等级 Precision grade							
1.0 Grade						1.0	
1.6 Grade						1.6	
2.5 Grade						2.5	
其他 Others						Others(note)	
附件可选 Optional accessories							
阻尼器 Damper						ZN	
散热器 Radiator						SR	
过压保护器 Overvoltage protection device						OP	
冷凝管 Siphon tube						SP	
其他 Others						文字注明 Text description	

注: 专用压力表壳需特殊材质时, 订货时请在型号后面注明。

Note: when the special pressure shell needs special materials, please specify behind the model when ordering.

Φ40 (50) 表盘压力表

Diameter pressure gauge of small outer



产品特性

径向或轴向直接安装结构;
有机玻璃压膜式罩壳设计;
铁喷塑外壳, 铜内机;
M10×1螺纹连接;
2.5%精度等级;
测量范围0-0.1MPa至0-250MPa;
仪表型号标示;
40径向;
Y-40C。

Product characteristics

Axial direct mounting structure
Design of compact enclosure for organic glass
Iron spray shell, copper machine
M10 * 1 thread connection
2.5% accuracy level
Measurement range 0-0.1MPa to 0-250MPa
Instrument type designation
40 radial
Y-40C

具体尺寸

Specific dimension

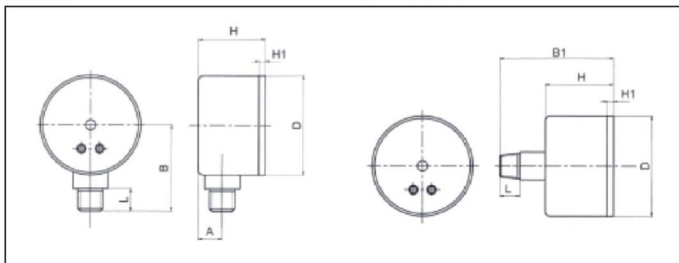

小外径压力表选型

Type selection of pressure gauge of small diameter

压力表Y Pressure gauge Y									
壳体+元件材质 Shell + element material									
碳钢+铜 Carbon steel + copper	无代码 No coding								
不锈钢+不锈钢 Stainless steel + stainless steel	B								
压力表类别 Pressure gauge type									
防震 Shock-resistance	N								
连接符号 Connection symbol									
	-								
表盘直径 Diameter of the gauge disc									
φ40						40			
φ50						50			
其他 Others						其他 Others			
安装方式 Installation method									
径向直接安装 Bottom mounting									
径向带后边凸装 Bottom mounting with back flange	无代码 No coding								
径向带前边嵌装 Bottom mounting with front flange	T								
轴向直接安装 Back mounting	Q								
轴向带后边凸装 Back mounting with back flange	Z								
轴向带前边嵌装 Back mounting with front flange	ZT								
	ZQ								
过程连接 Process connection									
M14×1.5						M14×1.5			
其他 Others						文字说明 Text description			
精度等级 Precision grade									
2.5 Grade								2.5	
其他 Others								Others(note)	
附件可选 Optional accessories									
阻尼器 Damper								ZN	
散热器 Radiator								SR	
过压保护器 Overvoltage protection device								OP	
冷凝管 Siphon tube								SP	
其他 Others								文字注明 Text description	

Φ200, 250表盘压力表

Pressure gauge with large outer diameter



产品简介

外径200、250mm一般压力表适合于在高大体积的设备上对无爆炸、不结晶及对铜合金不起腐蚀作用的液体或气体压力进行测量。或选用券不锈钢材质。

技术参数

执行标准: GB/T 1226-2001;
精度等级: 1.6%;
测量范围: -0.1~250MPa;
波登管/接头: 磷青铜波登管与黄铜接头锡焊接;
(可选全不锈钢材质);
仪表外壳: 不锈钢/碳钢;
仪表安装: 径向结构, M20×1.5 螺纹直接安装 (其他特殊标准可选);
表盘: 白色铝制, 黑色刻线;
指针: 铝制, 黑色;
表玻璃: 普通玻璃, 钢化玻璃 (可选);
正常工作环境温度: -40°C~+70°C。

几何尺寸

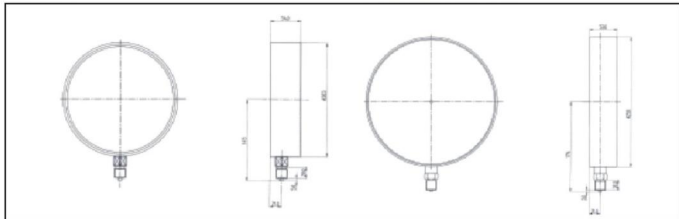

Product introduction

The general pressure gauge with 200, 250mm outer diameter is suitable for measuring the pressure of the liquid or gas of non-explosion and non-crystal and non-erosive to copper on the high dimensional device.

Technical parameter

Executive Standard: GB/T 1226-2001
Precision grade: 1.6%
Measurement range: -0.1MPa~250MPa
Bourdon tube / socket: phosphor bronze Bourdon tube and brass solder joints (whole stainless steel material is also optional)
Instrument shell: Stainless steel/carbon steel
Instrument installation: radial structure, M20×1.5 screw thread direct mounting (other special standard optional)
Gauge disc: white aluminum, black line
Pointer: Aluminum, black
Gauge glass: Common glass, Tempered glass (optional)
Normal working environment temperature: -40°C~+70°C

Geometry dimension

大外径压力表选型

Type selection of pressure gauge of large outer diameter

压力表Y Pressure gauge Y									
壳体+元件材质 Shell + element material									
碳钢+铜 Carbon steel + copper	无代码 No coding								
不锈钢+不锈钢 Stainless steel + stainless steel	B								
压力表类别 Pressure gauge type									
防震 Shock-resistance	N								
连接符号 Connection symbol									
	-								
表盘直径 Diameter of the gauge disc									
φ200	200								
φ250	250								
安装方式 Installation method									
径向直接安装 Bottom mounting	无代码 No coding								
其他 Others	文字说明 Text description								
过程连接 Process connection									
M20×1.5	M20×1.5								
其他 Others	文字说明 Text description								
精度等级 Precision grade									
1.6 Grade	1.6								
其他 Others	Others(note)								
表壳填充液 Filling liquid for the gauge shell									
硅油 (低粘度) Silicone oil (low viscosity)							H		
硅油 (高粘度) Silicone oil (high viscosity)							I		
甘油 Glycerol							J		
附件可选 Optional accessories									
阻尼器 Damper								ZN	
散热器 Radiator								SR	
过压保护器 Overvoltage protection device								OP	
冷凝管 Siphon tube								SP	
其他 Others									文字注明 Text description

一般电接点压力表

Pressure gauge of general electriccontacting point



产品简介

电接点压力表适用于测量对铜合金无腐蚀性、无爆炸危险、非结晶的各种液体、气体等介质的压力。

Product introduction

The electric contacting point pressure gauge is suitable for measuring the pressure of the medium such as the liquid and gas with no corrosion to copper alloy, no explosion risk and non-crystal.

产品分类

电接点压力表品种可分为直接作用式和磁助直接作用式，具体电气参数如下表：

Product classification

The electric contact pressure gauge can be divided into direct action type and direct action type and the specific electric parameters are as follows:

接点形式 Contacting pint type	直接作用式 Direct acting type	磁助直接作用式 Direct acting type with magnetic field
额定功率 Rated power	10	30
最高工作电压 Maximum operating voltage	380	
最大允许电流 Maximum allowable current	0.7	1.0、3
精度等级 Grade of precision	1.0, 1.6, 2.5	
测量范围 (MPa) Grade of precision	0~0.1, 0.16, 0.25, 0.4, 0.6, 1, 1.6, 2.5, 4, 6 0~10, 16, 25, 40, 60, 100, 160, 250 -0.1~-0.06, 0.15, 0.3, 0.5, 0.9, 1.5, 2.4	

执行标准：JB/T9273-1999

Executive standard: JB/T9273-1999

一般电接点压力表

Pressure gauge of general electric contacting point

压力表Y Pressure gauge Y								
电接点形式 Type of electric contacting point								
直接作用式 Direct acting type								
磁助直接作用式 Direct acting type with magnetic field		X	XC					
压力表类别 Pressure gauge type								
耐震 Shock-resistance		N						
连接符号 Connection symbol								
连接符号 Connection symbol								
表盘直径 Diameter of the gauge disc								
φ60						φ60		
φ100						φ100		
φ150						φ150		
其他 Others						其他 Others		
安装方式 Installation method								
径向直接安装 Bottom mounting						无代码 No coding		
其他 Others						文字说明 Text description		
过程连接 Process connection								
M14×1.5						M14×1.5		
M20×1.5						M20×1.5		
NPT 1/2						NPT 1/2		
其他 Others						文字说明 Text description		
精度等级 Precision grade								
1.0 Grade							1.0	
1.6 Grade							1.6	
2.5 Grade							2.5	
其他 Others							Others(note)	
附件可选 Optional accessories								
阻尼器 Damper							ZN	
散热器 Radiator							SR	
过压保护器 Overvoltage protection device							OP	
冷凝管 Siphon tube							SP	
其他 Others							文字注明 Text description	

不锈钢耐震电接点压力表

Stainless steel vibration-proof pressure gauge with electric contacting point



应用

主要测压元件及仪表外壳均采用不锈钢材料设计，适于测量腐蚀性较强的气体及液体的压力。通过对表体内充油，利用液体阻尼确保无振动显示，适用于测量介质强烈脉动及环境震动较大的场所。

与隔离体的配接

以上各类型的仪表均可与本公司生产的使用不同材料膜片的隔离体配接，组成隔膜式电接点压力表，适用于测量多种腐蚀性较强及粘度大易结晶介质的压力。

Application

The main pressure measuring element and the instrument shell are all designed with stainless steel material, which is suitable for measuring the pressure of gas and liquid with strong corrosion. The body is filled with oil and liquid damping is used to ensure no vibration. It is suitable for measuring the medium with strong pulsation and medium in vibrations place.

Matching with isolated body

The above various types of instruments can all be connected to isolated bodies using the different materials and diaphragms to form a electric contacting point pressure gauge of diaphragm type. It is suitable for measuring the medium of a variety kinds with strong corrosive and adhesive properties.

主要技术参数

Main technical parameters

测量范围 Measuring range	最小: 0~0.1MPa 最大: 0~250 MPa Minimum: 0~0.1MPa, Maximum: 0~250 MPa 负压范围: -0.1~2.4MPa Negative pressure range: -0.1~2.4MPa
指示精度 Indication precision	$\varphi 60$: 2.5% $\varphi 100/\varphi 150$: 1.6% (1.0%可选) $\varphi 60$: 2.5% $\varphi 100/\varphi 150$: 1.6% (1.0% optional)
最高工作电压 Maximum operating voltage	AC380V或DC220V
最大工作电流 Maximum operating current	3A
防护等级 Protection level	IP66
仪表玻璃 Instrument glass	普通玻璃、安全玻璃 Ordinary glass, safety glass

电气线路连接示意图

The connection diagram of the electric wiring

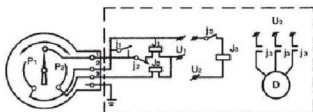

不锈钢耐震压力表选型

The selection of stainless steel vibration proof pressure gauge

压力表Y Pressure gauge Y									
电接点形式 Type of electric contacting point									
直接作用式 Direct acting type									
磁助直接作用式 Direct acting type with magnetic field		X							
壳体+元件材质 Shell + element material									
碳钢+铜 Carbon steel + copper									
不锈钢+不锈钢 Stainless steel + stainless steel		无代码 No coding							
压力表类别 Pressure gauge type									
耐震 Shock-resistance									
不耐震 Non-shock resistance								N	
配隔膜体 With diaphragm body									
不配隔膜体 Without diaphragm body		无代码 No coding							
隔膜螺纹 Diaphragm thread		无代码 No coding							
隔膜法兰 Diaphragm flange		ML							
		MF							
连接符号 Connection symbol									-
表盘直径 Diameter of the gauge disc									
φ60									φ60
φ100									φ100
φ150									φ150
其他 Others									其他 Others
安装方式 Installation method									
径向直接安装 Bottom mounting									无代码 No coding
其他方式 Others									文字说明 Text description
过程连接 Process connection									
法兰连接 Flange connection									文字说明 Text description
螺纹连接 Thread connection									文字说明 Text description
膜片材质 Diaphragm material									
316L SS									316
H.C合金 H.C alloy									H.C
Ta									Ta
Ti									Ti
蒙乃尔 Monel									蒙乃尔 Monel
316喷四氟 316 Spraying PTFE									316+PTFE
其他 Others									文字说明 Text description
精度等级 Precision grade									
1.0 Grade									1.0
1.6 Grade									1.6
2.5 Grade									2.5
其他 Others									Others(note)
表壳填充液 Filling liquid for the gauge shell									
硅油 (低粘度) Silicone oil (low viscosity)									H
硅油 (高粘度) Silicone oil (high viscosity)									I
甘油 Glycerol									J
附件可选 Optional accessories									
阻尼器 Damper									ZN
散热器 Radiator									SR
过压保护器 Overvoltage protection device									OP
冷凝管 Siphon tube									SP
其他 Others									文字注明 Text description

注：配隔膜体时，壳体和元件材质必须为不锈钢。

Note: when equipping the diaphragm model, the shell and components must be made of stainless steel.

氨专用电接点压力表

Specialized electric contacting point pressure gauge for Ammonia



产品简介

氨专用电接点压力表采用弹簧管作为测压敏感元件，主要用于氨气压力的测量。并通过仪表指针的触点与设定指针的触点相接通（断开）控制系统中电路的开关，以达到自动控制 and 报警信号的目的。本仪表可与各类膜片隔离器相连接，制成隔膜电接点压力表，用于测量腐蚀性强、粘度大、易结晶介质的压力。

Product introduction

The specialized pressure gauge with electric contacting point for ammonia uses the spring as the pressure measuring element, which is mainly used in the measurement of ammonia pressure. The switch of the circuit in the control system is switched on by the contact point of the instrument pointer and by setting up the pointer so as to achieve the goal of automatic control and alarm signal. This instrument can be connected with all kinds of diaphragm separator to make the diaphragm electric contact pressure gauge for measuring the pressure of material with corrosion resistance, high viscosity and crystal.

主要技术参数

执行标准: JB/T9272-1999
测量范围: 最小: 0~0.1MPa 最大: 0~250 MPa
负压范围: -0.1~2.4MPa
指示精度: $\pm 1.6\%$
防护等级: IP66
最高工作电压: AC380V或DC220V
最大电流: 3A
环境温度: -40~+70°C
环境影响: 使用温度偏离 $\pm 25^\circ\text{C}$ 时, 其设定点误差变化不大于0.6%/10°C

Main technical parameters

Execution standard: JB/T9272-1999
Measurement range: minimum: 0~0.1MPa maximum: 0~250 MPa
negative pressure range: -0.1~2.4MPa
Indication accuracy: $\pm 1.6\%$
Protection level: IP66
Maximum operating voltage: AC380V or DC220V
Maximum current: 3A
Ambient temperature: -40~+70 °C
Environmental impact: the usage temperature is deviated to $\pm 25^\circ\text{C}$, the fixed point error is not greater than 0.6%/10°C

外形尺寸

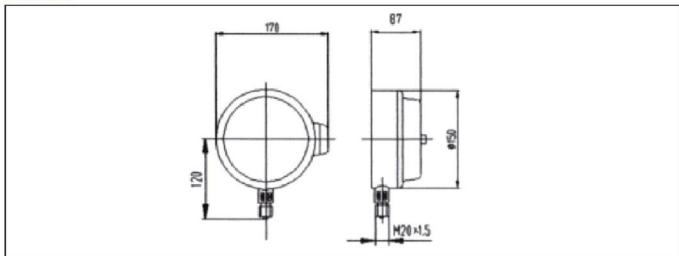

氨专用电接点压力表选型

Type selection of electric contacting points pressure gauge for ammonia

压力表Y Pressure gauge Y								
电接点形式 Type of electric contacting point								
直接作用式 Direct acting type								
磁助直接作用式 Direct acting type with magnetic field		X						
		XC						
压力表类别 Pressure gauge type								
耐震 Shock-resistance								
不耐震 Non-shock resistance		N						
连接符号 Connection symbol								
		-						
表盘直径 Diameter of the gauge disc								
φ60								φ60
φ100								φ100
φ150								φ150
其他 Others								其他 Others
安装方式 Installation method								
径向直接安装 Bottom mounting								无代码 No coding
其他 Others								文字说明 Text description
过程连接 Process connection								
M14×1.5								M14×1.5
M20×1.5								M20×1.5
其他 Others								文字说明 Text description
精度等级 Precision grade								
1.0 Grade								1.0
1.6 Grade								1.6
2.5 Grade								2.5
其他 Others								Others(note)
附件可选 Optional accessories								
无附件 No accessory								无 (可省略) No (omitted)
阻尼器 Damper								ZN
散热器 Radiator								SR
过压保护器 Overvoltage protection device								OP
冷凝管 Siphon tube								SP
其他 Others								文字注明 Text description

注: 对壳体有特殊要求的, 订货前请注明。

Note: If you have special requirements for the shell, please specify it before placing an order.

微压膜片电接点压力表

Electric contacting point pressure gauge of micro pressure diaphragm



产品简介

膜片电接点压力表采用膜片作为测压敏感元件，并可根据不同的测量介质选用不同材料的膜片。本仪表主要用于工业过程中对气体、液体压力微小压力的测量，尤其适用于腐蚀性粘稠介质（非凝固、非结晶）的微小压力测量，并通过仪表指针的触点与设定指针的触点相接通过（断开）控制系统中电路的开关，以达到自动控制 and 自动报警功能。

产品特性

1. 测量压力最低可达0.2KPa;
2. 可根据不同测量介质的防腐要求可选择多种不同的膜片;
3. 仪表可制作成充油耐震型应用于工作环境有震动的场所。

主要技术参数

仪表类型 Instrument type	普通型、耐震型（充油） General type, vibration proof type (oil)
指示直径 Indicator diameter	φ100, φ160
精度 Precision	1.6 Grade
接点材质 Material of contacting point	≥110V银镍合金, ≤36V黄金 ≥110V Silver nickel alloy, ≤36V gold
测量范围 Measuring range	正压0~0.2KPa/0~4KPa/0~100KPa 正压压力0~0.2KPa/0~4KPa/0~100KPa 负压-0.2KPa/-0.2~0KPa/-100~0KPa及任何相关正负压力量程 Negative pressure -0.2KPa/0.2~0KPa to -100~0KPa and any relevant positive and negative pressure range
膜片材质 Diaphragm material	304, 316, 喷涂PTFE 304, 316, spraying PTFE
接头材质 Joint material	304, 316
外壳材质 Shell material	304
防护等级 Protection level	IP66
最高工作电压 Maximum operating voltage	380VAC或220VDC 380VAC or 220VDC
最大电流 Maximum current	1A
环境温度 Ambient temperature	普通型: -40~+70℃ 耐震型: -20~+60℃ Common type: -40~70℃, vibration proof type: -20~80℃
连接尺寸 Connection dimension	螺纹连接M20×1.5, 法兰连接按标准, 特殊连接需面询后在订货前注明 Threaded connection M20×1.5, flange connection according to the standard, for the special connection, it must be specified before ordering

Product introduction

Diaphragm electric contacting point pressure gauge uses the diaphragm as a pressure sensitive components and different materials of the diaphragm can be used according to different measurement media. This instrument is mainly used for measuring pressure of gas or liquid with micro pressure in industrial processes, especially for corrosive viscous medium (non solidification, non crystalline) micro pressure measurement. The circuit in the system is controlled through the contacting pint and setting the pointer connector(disconnection) so as to achieve automatic control and automatic alarm function.

Product characteristics

1. Minimum pressure of measurement is as low as 0.2KPa
2. A variety of different diaphragm can be used according to the requirements of erosion-resistance of different media
3. The gauge can be made into oil-filling type used in work environment with vibration.

Main technical parameters

微压膜片压力表选型

Type selection of micro pressure diagram

微压膜片压力表 YPXC Electric contacting point pressure gauge of micro pressure diagram YPXC								
压力表类别 Pressure gauge type								
耐震 Shock-resistance	无代码 No Coding							
不防震 Non-shock resistance	N							
连接符号 Connection symbol	-							
表盘直径 Diameter of the gauge disc								
φ100	φ100							
φ160	φ160							
过程连接 Process connection								
M20×1.5	M20×1.5							
法兰连接 Flange connection	文字说明 Text description							
其他 Others	文字说明 Text description							
膜片材质 Diaphragm material								
316L SS	316							
H.C合金 H.C alloy	H.C							
Ta	Ta							
Ti	Ti							
蒙乃尔 Monel	蒙乃尔 Monel							
316喷涂氟 316 Spraying PTFE	316+PTFE							
其他 Others	文字说明 Text description							
精度等级 Precision grade								
1.6 Grade	1.6							
其他 Others	Others(note)							
表壳填充液 Filling liquid for the gauge shell								
硅油 (低粘度) Silicone oil (low viscosity)							H	
硅油 (高粘度) Silicone oil (high viscosity)							I	
甘油 Glycerol							J	
附件可选 Optional accessories								
阻尼器 Damper								ZN
散热器 Radiator								SR
过压保护器 Overvoltage protection device								OP
冷凝管 Siphon tube								SP
其他 Others								文字注明 Text description

YT系列防爆电接点压力表

Explosion-proof electric contacting point pressure gauge of YT series

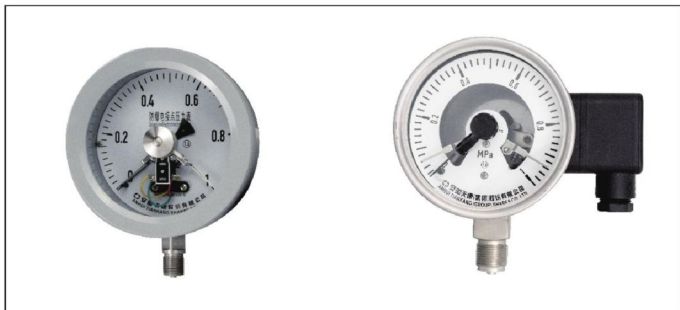

用途

本仪表用在环境有爆炸性混合物的危险场所，用来测量对铜及铜合金，普通碳钢等无腐蚀性的非结晶，非凝固介质的压力（负压）。

通过接点装置与具有相应防爆性能的电气配件使用。对被测介质压力，有自动控制、报警、信号远传等多种功能。

本仪表系我公司按国家标准：GB/T1226-2001《一般压力表》国家标准GB3836.1-2000《爆炸性气体环境用电气设备第一部分：通用要求》；GB3836.2-2000《爆炸性气体环境用电气设备第9部分：隔爆型“d”》，产品标准：Q/CYJ 02.03-2011《防爆电接点压力表》规定设计、制造。

本仪表的防爆类别为隔爆型，其防爆标志ExdⅡBT6Gb。

Usage

The instrument is used in the environment of dangerous places with explosive mixture and it is used to measure the pressure of copper and copper alloy, ordinary carbon steel and other material of non-corrosive, non-crystalline and non-solidification medium (negative pressure).

It is used along with the electric components with corresponding explosion-proof performance through the contact device. For the measured media pressure, it has the functions of automatic control, alarming and remote signal etc.

The gauges are designed and produced by our company according to the national standard: GB/T1226-2001 "general pressure gauge" national standard; GB3836.1-2000 "electrical apparatus for explosive gas atmospheres Part 1: General Requirements"; GB3836.2-2000 "electrical apparatus of explosive gas environment Part 9: Flameproof Enclosures "d"; product standard: Q/CYJ02.03-2011 "pressure gauge of explosion-proof electric contacting point" regulations.

Explosion proof class of this instrument is an explosion-proof type and its explosion-proof mark is: Ex d Ⅱ BT6 Gb.

仪表名称 Name of instrument	测量范围 Measuring range	精度等级 Precision grade	接点参数 Contact points parameters	仪表重量 (Kg) Instrument weight	
防爆电接点压力表 Explosion proof electric connection point pressure gauge	0~250 MPa	1.6%	触头功率 Power of the contacting point 10伏安 10 Kva	€ 100	€ 150
防爆电接点真空表 Explosion proof electric connection point vacuum gauge	-0.1~0 MPa	1.6%		€ 100	€ 150
防爆电接点压力真空表 Explosion proof electric connection Point pressure vacuum gauge	-0.1~2.4MPa	1.6%		€ 100	€ 150
磁助式防爆电接点压力表 Magnetic flux control electric contact points pressure gauge	0~250 MPa -0.1~0 MPa -0.1~2.4MPa	1.6%	触头功率 Contacting point power 30伏安 30 Kva	€ 100	€ 150

标度范围、精确度等级 Scale range and accuracy class

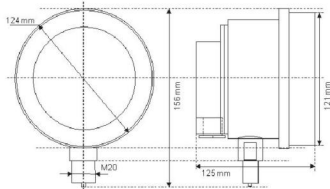

YTXB-150外型尺寸 YTXB-150 dimension

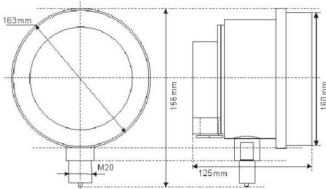

结构与工作原理 Structure and working principle

- 1、仪表外壳采用防爆结构，当其外壳内部的爆炸性混合物因受到火花或电弧影响，发生爆炸时，不至引起外部爆炸性混合物爆炸，从而达到防爆的目的。
- 2、仪表由弹簧管压力表和一个电接装置组成。仪表工作原理：当被测介质进入弹簧管，使其产生的位移，经过传动机构放大后，指针将被测压力值，在刻度盘上指示出来，同时指针带动电接装置的活动触头，当压力达到预定值时，活动触头与设定针的触头接触，接通电路。
- 3、进线橡胶密封圈内径 $\phi 10\text{mm}$ ，邵尔氏硬度45-55配用电缆外径 $\phi 9.8\text{mm}$ ，500VBX型肆芯橡皮线（4X1）。
- 4、接线方式：

Structure and working principle

1. The instrument shell adopts flameproof structure, when the explosive mixture inside the casing face the explosion due to arc or spark effect, it will not cause external explosive of the mixture material, thus achieving the explosion-proof purpose.
2. The instrument is composed of a spring tube pressure gauge and an electric connection device. The meter work principle: when the measured medium enters into the spring, the displacement will be generated, transmitted after amplification, the pointer will be measured for the pressure value and indicated on the dial. At the same time, the pointer drives the movable contact point of electric contact device. When the pressure reaches a predetermined value, the movable contacting pointer will contact with the preset one.
3. The diameter of the rubber sealing ring is $\phi 10\text{mm}$, shore hardness 45-55 with cable diameter: 9.8mm , 500VBX core shirr (4X1)
4. Wiring method:

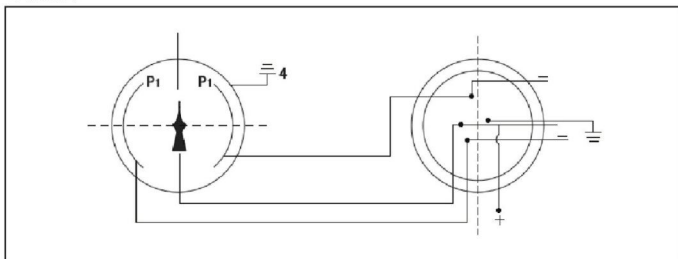

防爆电接点压力表选型

Type selection of explosion proof electric contacting point pressure gauge

防爆电接点压力表 YT Explosion proof electric contacting point pressure gauge YT									
电接点形式 Type of electric contacting point									
直接作用式 Direct acting type		X							
磁助直接作用式 Direct acting type with magnetic field		XC							
壳体+元件材质 Shell + element material									
碳钢+铜 Carbon steel + copper		无代码 No coding							
不锈钢+不锈钢 Stainless steel + stainless steel		B							
压力表类别 Pressure gauge type									
耐震 Shock-resistance		无代码 No Coding							
不耐震 Non-shock resistance		N							
配隔膜体 With diaphragm body		无代码 No coding							
不配隔膜体 Without diaphragm body		无代码 No coding							
隔膜螺纹 Diaphragm thread		ML							
隔膜法兰 Diaphragm flange		MF							
连接符号 Connection symbol		-							
表盘直径 Diameter of the gauge disc									
φ100		φ100							
φ150		φ150							
其他 Others		其他 Others							
安装方式 Installation method									
空间直接安装 Bottom mounting		无代码 No coding							
其他 Others		文字说明 Text description							
过程连接 Process connection									
法兰连接 Flange connection		文字说明 Text description							
螺纹连接 Thread connection		文字说明 Text description							
膜片材质 Diaphragm material									
316L SS		316							
H.C合金 H.C alloy		H.C							
Ta		Ta							
Ti		Ti							
蒙乃尔 Monel		蒙乃尔 Monel							
316膜四氟 316 Spraying PTFE		316+PTFE							
其他 Others		文字说明 Text description							
精度等级 Precision grade									
1.0 Grade		1.0							
1.6 Grade		1.6							
2.5 Grade		2.5							
其他 Others		文字说明 Text description							
壳体填充液 Filling liquid for the gauge shell									
硅油 (低粘度) Silicone oil (low viscosity)									H
硅油 (高粘度) Silicone oil (high viscosity)									I
甘油 Glycerol									J
附件可选 Optional accessories									
阻尼器 Damper									ZN
散热器 Radiator									SR
过压保护器 Overvoltage protection device									OP
冷凝管 Siphon tube									SP
其他 Others									文字注明 Text description

精密压力表

Precision pressure gauge

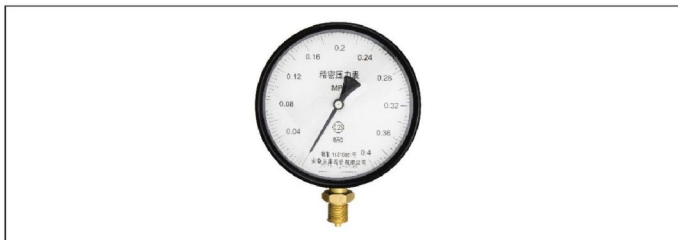

产品简介

精密压力表由测压系统、传动机构、指示装置和外壳组成。精密压力表的测压弹性元件经特殊工艺处理，使精密压力表性能稳定可靠，与高精度的传动机构配套调试后，能确保精确的指示精度。精密压力表主要用于校验工业用普通压力表，精密压力表也可在工艺现场精确的测量对铜合金和合金结构钢等材质无腐蚀性、非结晶、非凝固介质的压力。

Product introduction

The precision pressure gauge is composed of a pressure measuring system, a transmission mechanism, an indicating device and a casing. The elastic element of the precision pressure gauge is processed by special material so that the precision pressure gauge performance is stable and reliable. It can ensure the accuracy of the instructions after working along with the transmission mechanism. Precision pressure meter is mainly used to check the industrial normal pressure meter, precision pressure gauge can be used to precisely measure the medium pressure with no corrosion, no crystal and no solidification as copper alloy and alloy steel materials.

精密压力表量程与精度的对比表

Table of comparison between the measuring range and precision of precision pressure gauge

测量范围 (Mpa) Measuring range	0.4级精度 0.4 precision grade			0.25级精度 0.25 precision grade			0.16级精度 0.16 precision grade			工作介质 Working medium
	标尺分格数 Number of scales	最小分格值 (Mpa) The minimum scale number	允差值 (±) Permissible difference	标尺分格数 Number of scales	最小分格值 (Mpa) The minimum scale number	允差值 (±) Permissible difference	标尺分格数 Number of scales	最小分格值 (Mpa) The minimum scale number	允差值 (±) Permissible difference	
-0.1~0	200	0.0005	0.0004	200	0.0005	0.00025	400	0.00025	0.00016	气体 Gas
0~0.04	200	0.0002	0.00016	200	0.0002	0.00010	-	-	-	
0~0.06	120	0.0005	0.00024	300	0.0002	0.00015	-	-	-	
0~0.1	200	0.0005	0.0004	300	0.0005	0.00025	400	0.00025	0.00016	
0~0.16	160	0.001	0.00064	320	0.0005	0.0004	320	0.0005	0.000256	
0~0.25	125	0.002	0.001	250	0.001	0.000625	250	0.001	0.00040	
0~0.4	200	0.002	0.0016	200	0.002	0.001	400	0.001	0.00064	液体、气体 Liquid and gas
0~0.6	120	0.005	0.0024	300	0.002	0.0015	300	0.002	0.00096	
0~1	200	0.005	0.004	200	0.005	0.0025	400	0.0025	0.0016	
0~1.6	160	0.01	0.0064	320	0.005	0.004	320	0.005	0.00256	
0~2.5	125	0.02	0.01	250	0.01	0.00625	250	0.01	0.004	
0~4	200	0.02	0.016	200	0.02	0.01	400	0.01	0.0064	
0~6	120	0.05	0.024	300	0.02	0.015	300	0.02	0.0096	
0~10	200	0.05	0.04	200	0.05	0.025	400	0.025	0.016	
0~16	160	0.1	0.064	320	0.05	0.04	320	0.05	0.0256	
0~25	125	0.2	0.1	250	0.1	0.0625	250	0.1	0.04	
0~40	20	0.2	0.16	200	0.2	0.1	400	0.1	0.064	

测量范围 (Mpa) Measuring range	0.4级精度 0.4 precision grade			0.25级精度 0.25 precision grade			0.16级精度 0.16 precision grade			工作介质 Working medium
	标尺分格数 Number of scales	最小分格值 (Mpa) The minimum scale number	允差值 (±) (Mpa) Permissible difference	标尺分格数 Number of scales	最小分格值 (Mpa) The minimum scale number	允差值 (±) (Mpa) Permissible difference	标尺分格数 Number of scales	最小分格值 (Mpa) The minimum scale number	允差值 (±) (Mpa) Permissible difference	
0~60	200	200	0.24	300	0.2	0.15	300	0.2	0.096	液体、气体 Liquid and gas
0~100	200	200	0.4	200	0.5	0.25	500	0.2	0.64	
0~160	160	1	0.64	320	0.5	0.4	800	0.2	0.0256	
0~250	125	2	0.02	250	1	0.01	500	0.5	0.96	
-0.1~0.06	160	0.001	0.00064	160	0.001	0.0004	-	-	-	气体 Gas
-0.1~0.15	125	0.002	0.001	125	0.002	0.000625	-	-	-	
-0.1~0.3	200	0.002	0.0016	200	0.002	0.001	-	-	-	
-0.1~0.5	120	0.005	0.0024	120	0.005	0.0015	-	-	-	
-0.1~0.9	200	0.005	0.004	200	0.005	0.0025	-	-	-	
-0.1~1.5	160	0.01	0.0064	160	0.01	0.004	-	-	-	
-0.1~2.4	125	0.02	0.01	125	0.02	0.00625	-	-	-	
-0.04~0	200	0.0002	0.00016	200	0.0002	0.00010	-	-	-	
-0.06~0	120	0.0005	0.00024	120	0.0005	0.00015	-	-	-	
-0.04~0.02	120	0.0005	0.00024	120	0.0005	0.00015	-	-	-	
-0.04~0.06	200	0.0005	0.0004	200	0.0005	0.00025	-	-	-	
-0.04~0.12	160	0.001	0.00064	160	0.001	0.0004	-	-	-	
-0.04~0.21	125	0.002	0.001	125	0.002	0.000625	-	-	-	
-0.04~0.36	200	0.002	0.0016	200	0.002	0.001	-	-	-	
-0.06~0.1	160	0.001	0.00064	160	0.001	0.0004	-	-	-	
-0.06~0.19	125	0.002	0.001	125	0.002	0.000625	-	-	-	
-0.06~0.34	200	0.002	0.0016	200	0.002		0.001			液体、气体 Liquid and gas

注：精密压力表选型注意事项

- 1.先确定精密压力表的测量范围参数；
- 2.再通过同一行中分列的各分辨率参数进行对比来选择精密压力表的精度等级；
- 3.使用环境条件：-40~70℃，相对湿度不大于85%；
- 4.温度影响：使用温度偏离20±5℃时，不大于0.4%/10℃。

Note: matters to be concerned for the selection of precision pressure gauge

- 1 Determine the measurement range of precision pressure gauge;
- 2 Through the different parameters of resolution in the same row, the accuracy of precision pressure gauge is selected accordingly.
- 3 The usage environmental conditions: -40~70 °C, the relative humidity is not more than 85%.
- 4 Temperature effect: when the temperature is deviated from 20±5°C, it is not more than 0.4%/10°C.

主要技术指标

Main technical index

型号 Model	Y-150 YB-150
精度等级 Precision grade	0.4, 0.25, 0.16
测量范围MPa Measuring range	0~0.1, 0.16, 0.25, 0.4, 0.6, 1, 1.6, 2.5, 4, 6; 0~10, 16, 25, 40 0~10, 18, 25, 40, 60, 100, 160, 250; -0.1~0.06, 0.15, 0.3, 0.5, 0.9, 1.5, 2.4

精密压力表选型

Type selection for precision pressure gauge

压力表Y Pressure gauge Y						
壳体+元件材质 Shell + element material						
碳钢+铜 Carbon steel + copper	无代码 No coding					
不锈钢+不锈钢 Stainless steel + stainless steel	B					
连接符号 Connection symbol		-				
表盘直径 Diameter of the gauge disc						
φ150					φ150	
过程连接 Process connection						
M14×1.5					M14×1.5	
M20×1.5					M20×1.5	
G1/2					G1/2	
1/2"NPT					1/2"NPT	
其他 Others					文字说明 Text description	
精度等级 Precision grade						
0.4 Grade					0.4	
0.25 Grade					0.25	
其他 Others					文字说明 Text description	
附件可选 Optional accessories						
阻尼器 Damper						ZN
散热器 Radiator						SR
过压保护器 Overvoltage protection device						OP
冷凝管 Siphon tube						SP
其他 Others					文字注明 Text description	

YTZ电阻远传压力表

YTZ resistance transmission pressure gauge



结构原理

本仪表由一个普通弹簧管压力表和一组滑线电阻式发送器等组成。

当被测介质的压力变化时，弹簧管管端产生位移，该位移通过传动机构使指针在度盘上指示相应的压力值。由于滑线电阻式发送器设置在传动机构的扇形齿轮上，当传动机构产生偏转时，即带动滑臂电刷作相应的滑行，使被测压力值的变化转换成电阻的变化而传输到二次仪表上进行显示。

电阻远传压力表适用于测量对铜及铜合金不起腐蚀性作用的液体、蒸汽和气体等介质的压力。同时能把被测压力以电量值传输到远距离的二次仪表，以实现集中检测和远距离控制。并能在现场就地指示，便于工艺检查。

主要技术指标

精确度等级：1.6、2.5；

发送器起始电阻值：3~20Ω；

发送器满度电阻值：340~400Ω 发送器接线端①②外加电压不大于6V；

滑线电阻式发送器接线图

Structure principle

This instrument consists of one common spring tube pressure gauge and one group of slide resistance type of transmitters.

When the pressure of the medium being measured is changed, the spring tube end produces displacement and corresponding pressure value is indicated on the dial by the pointer for this displacement through drive mechanism. Since the slide resistance transmitter is set on the segment gear of the drive mechanism, when the drive mechanism deflects, i.e. drives the slide arm brush to make sliding, the change of pressure value being measured is converted to change of resistance and then transmitted to secondary meter and displayed.

Resistance remote transmission pressure gauge is applicable to measure the medium pressure of liquid, steam and gas which is not corrosive to copper and copper alloy. It is also able to transmit the electric value to the remote secondary meter so as to realize centralized detection and remote control. It is also able to make local indication on site, making the process check convenient.

Main technical index

Accuracy class: 1.5

Start resistance value of the transmitter: 3~20Ω

Full-scale resistance value of transmitter: 340~400Ω, the external voltage of wiring terminals ①② of the transmitter shall be no more than 6V.

Wiring diagram of slide resistance transmitter

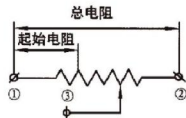

测量范围

使用环境条件：-40~70℃，相对湿度不大于85%，且震动和被测介质的急剧脉动应对仪表正常工作无明显影响。

温度影响：使用温度偏离20±5℃时，其温度附加误差 不大于0.4%/10℃。

重量：1.2kg

Measurement scope

Environmental conditions for operation: -40~70℃, relative humidity no more than 85% and the abrupt pulsation of the vibration and the measured (controlled) medium shall have no obvious influence on the normal operation of the instrument.

Temperature influence: when the operation temperature deviates by 20±5℃, the additional error of the temperature shall be no more than 0.4%/10℃.

Weight: 1.2kg

测量范围 Measurement scope
0~0.1;0~0.16;0~0.25;0~0.4;0~0.6;0~1.0~1.6, 0~2.5;0~4~6~0~10~16;0~25;0~40~0~60
-0.1~0;-0.1~0.06;-0.1~0.15;-0.1~0.3;-0.1~0.5;-0.1~0.9;-0.1~1.5;-0.1~2.4

配套接线图

与XMY-10压力数字显示仪配套
与XMY-12压力数字显示控制仪配套

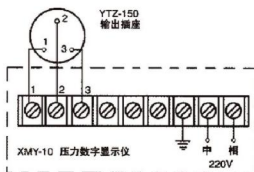

Supporting wiring diagram

Used with XMY-10 pressure digital display instrument
Used with XMY-12 pressure digital display control meter

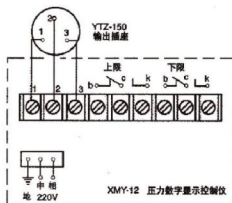

电阻远传压力表选型

Type selection of transmission pressure gauge

电阻远传压力表 Resistance transmission pressure gauge YZZ					
壳体+元件材质 Shell + element material 碳钢+铜 Carbon steel + copper 不锈钢+不锈钢 Stainless steel + stainless steel	无代码 No coding B				
连接符号 Connection symbol	-				
表盘直径 Diameter of the gauge disc φ150	φ150				
过程连接 Process connection M20×1.5 G1/2 1/2"NPT 其他 Others	M20×1.5 G1/2 1/2"NPT 文字说明 Text description				
精度等级 Precision grade 1.6 Grade 2.5 Grade 其他 Others	1.6 2.5 文字说明 Text description				
附件可选 Optional accessories 阻尼器 Damper 散热器 Radiator 过压保护器 Overvoltage protection device 冷凝管 Siphon tube 其他 Others				ZN SR OP SP 文字注明 Text description	

YCA系列双膜片高静压差压力表

YCA Series Double-diaphragm High Static Pressure Differential Pressure Gauge



产品简介

双膜片式高静压差压力表主要用于过滤器的正负压力表,液体罐液位、泵出入口、输气管线和加压站等场合的压力差测量。本差压表具有较高的耐压性能,并能适用于有腐蚀性的环境中使用。

主要技术指标

仪表直径: 100、150 (mm) ;
精度等级: 2.5% (可选1.6%) ;
测量范围: 最低0-1kPa, 最高0-1.6MPa;
防护等级: IP66;
工作环境温度: -20°C~70°C;
过程连接: M20×1.5、G1/2、NPT1/2或其他定制螺纹;
膜片材质: 负压316L、正压316Ti;
接头材质: 316;
表壳材质: 304;
机芯材质: 304;
仪表玻璃: 防爆双层安全玻璃;
表针: 调零表针 黑色铝;
表盘: 铝白底黑刻度字。

工作压力及使用范围

最大静压值: 20MPa;
动压: 0.7倍满量程;
过压保护: 双边耐压10MPa;
如有其它特殊要求, 须经我公司技术确认后可定制。

Product introduction

The double-diaphragm high static pressure differential pressure gauge is mainly applied for measuring the pressure difference in the positive and negative pressure sides of filter, liquid level of liquid pot, accesses of pump, gas transmission pipeline and pressure station. This differential pressure gauge has high pressure-resistant property, and can be adaptable in corrosive environment.

Main Specifications

Diameter of instrument: 100, 150 (mm)
Accuracy class: 2.5% (alternative class as 1.6%)
Measurement range:
Minimum 0-1kPa
Maximum 0-1.6MPa
Protection grade: IP66
Operating environment temperature: -20°C~70°C
Procedure linkage: M20×1.5, G1/2, NPT1/2 or other customized threads
Materials of diaphragm: 316L of negative pressure, 316Ti of positive pressure
Joint material: 316
Watch case material: 304
Movement material: 304
Instrument glass: explosion-proof double-deck non-shatterable glass
Watch needle: zero setting watch needle, colored in black, and materialized as Aluminum
Dial: materialized as Aluminum, black graduated characters on white background.

Working pressure and application range

Maximum static pressure: 20MPa.
Dynamic pressure: 0.7 time of full scale
Over-voltage protection: withstand voltage on each side, 10MPa.
If other special requirements occur, the instrument can be customized after confirmed technically by our company.

产品分类

Product classification

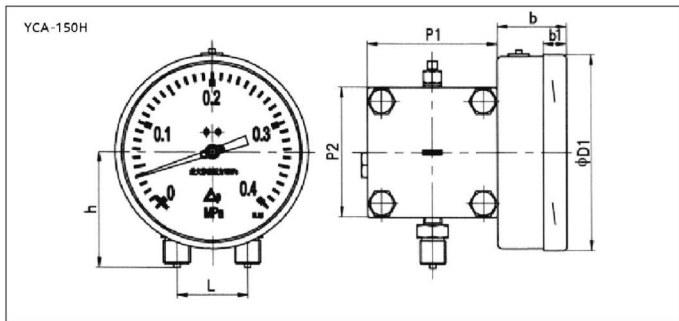
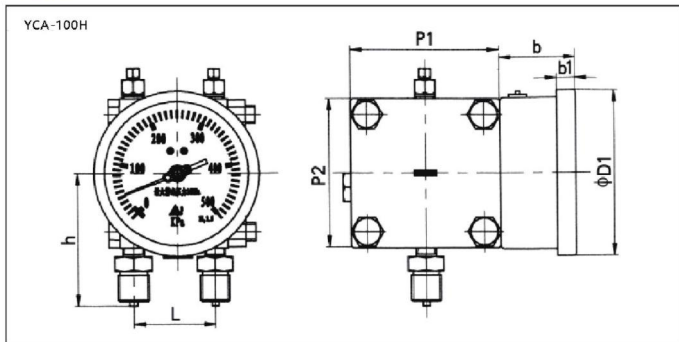

型号 Model	几何尺寸 Geometry size					
	fl D1	b1	b	P1P2	L	h
YCA-100H	110	110	51.5	100	54	100
YCA-150H	149	149	53.5			

产品外形尺寸

(1) 后背板安装

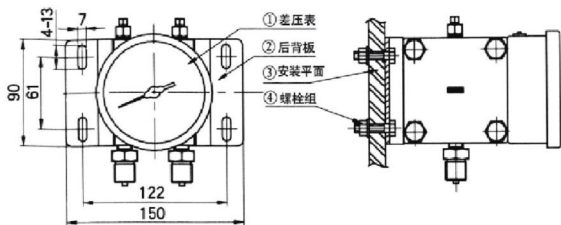

- 注：1、后背板只适合平面安装（如仪表板、机器外表平面等）；
2、注意平面要坚固，使差压表安装后牢固，不会发生掉落；
3、特殊后背板可按客户要求求出加工成煎架梯加工。

Products overall dimensions

(1) Installation of rear panel

- Note: 1.The rear panel is merely adoptable to be installed on the surface (instrument board and external surface of machine).
2.The surface is required to be solid as to stabilize the differential pressure gauge after installation and to prevent the dropping of gauge.
3.The special rear panel can be illustrated and processed in accordance with customer's requirement or with customer's materials.

(2) 固定支架安装

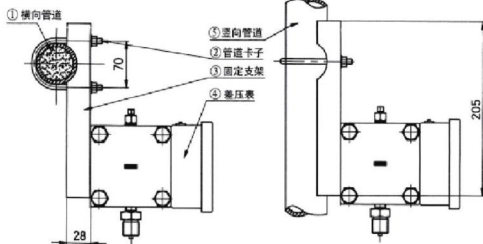

- 注：1、固定支架安装只适用于管道安装（横向或竖向）；
2、注意管道的外径不能大于60mm；
3、仪表可以装到支架上方或下方，方便用户自由选择。

(2) Installation for fixed support

- Note:1.The fixed support is merely adoptable to be installed in pipeline (crosswise or vertical).
2.Please note that the outer diameter of pipeline shall be no more than 60mm.
3.The gauge can be installed either on or beneath the support, and this shall be determined by customers.

三阀组的安装、拆卸及使用方法

Installation, disassemble and application method of three-valve manifold

安装

Installation

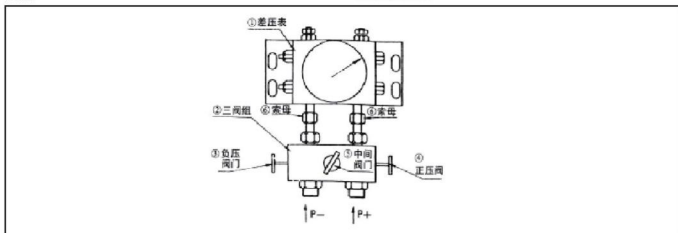

1. 正常使用差压表必须配三阀组或五阀组以保护差压表正常工作。
2. 差压表和三阀组用两个螺母紧固。螺母和差压表接头密封面应加四氟垫片。
3. 装有三阀组的差压表在使用前必须把中间阀门打开，并把正压阀门和负压阀门打开。（当P+和P-任意的压力先进入时，中间阀门能起到平衡差压表两腔体内的压力的作用，以免打坏差压表。
4. 当P+、P-的压力正常进入三阀组后，再关闭中间阀门使差压表正常工作。如差压表表针有轻微高零属正常，只需把表针调到零位即可（注意必须用肥皂水检验所有密封口是否泄漏，如有泄漏必须紧固。）
5. 差压表有后背板式安装（如图）和立管固定方法。（管卡子卡到管子上）

1. To guarantee the normal application of differential pressure gauge, the three valves manifold or five valves manifolds shall be equipped.
2. The differential pressure gauge and three valves manifolds are fastened by two locknets. PTFE spacer shall be embedded between lock net and differential pressure gauge.
3. The middle valve of differential pressure gauge equipped with three valves manifold shall be opened before using this gauge, and in the meantime the positive pressure valve and negative pressure valve shall be opened. (While any pressure amount of P+ and P- is entered, the middle valve shall exert the function of balancing the pressure inside two cavities of differential pressure gauge as to protect the ffg gauge from being broken.)
4. Once the pressure of P+ and P- is normally entered in the three valves manifolds, the middle valve shall be closed as to guarantee the regular functioning of the differential pressure gauge. If the watch needle of differential pressure gauge is fluctuated around the zero setting, set the watch needle back to the zero. (Note that all the seals shall be checked for leakage. If the leakage occurs, the seal must be fastened.)
5. The rear-panel installation instruction (as shown below) and the stand pipe fixation method are presented on the back of differential pressure gauge. (pipe clamp is clamped on the pipe)

拆卸

Disassemble

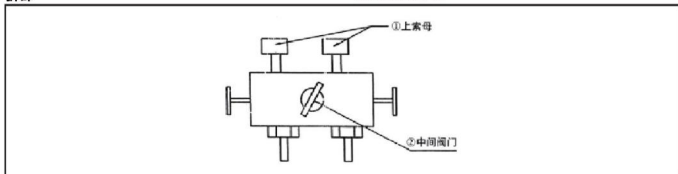

1. 首先打开三阀组的中间阀门，并打开正压和负压阀门（正压负压阀门原皆为打开）
2. 关闭进气两个阀门（在设备的主管道上）
3. 拆下更换仪表(即两个螺母)注意用板子卡住差压表的接头，只拆三阀组上的上螺母。先松开一点放空压力，再把卡到管子上的卡子螺母松开，并把卡子取下。
4. 再把三阀组上的两个螺母慢慢松开把差压表取下。（注意一定要两个螺母同时松）

1. The middle valve of the three valves manifold shall be firstly opened, and the positive pressure and negative pressure valves shall be opened. (the positive pressure and negative pressure valves are originally opened)
2. Two valves of inlet valve shall be closed. (on the main pipe of the instrument)
3. The gauge is disassembled and replaced (two lock nets are disassembled). Clamp the joint of differential pressure gauge, and merely disassemble the up lock net of three valves manifold. Slightly unscrew the lock net as to release the pressure, and then screw off the clamp nut clamped on the pipe. Afterwards disassemble the clamp.

5. 拆新表装上的方法同上面安装方法最好换上两个新的四氟垫（确保不漏）

6. 把卡子卡好

7. 先开总开关（两个再关上差压表三阀组中间的阀门（新接口用肥皂水试漏）

8. 两分钟后把差压表表针调到零位。（如没有轻微高零不用调整）

注：在装表或卸表时，必须保证中间阀门和P+、P-两个阀门全部开启，以确保仪表能正常使用。

4. Two lock nets on the three valves manifold are slowly screwed off gradually (the disassembling of two locknets shall be initiated simultaneously)

5. The installing method of new gauge is similar to the installation method mentioned above. It is advised to renew two PTFE space-rs. (as to guarantee the non-leakage condition)

6. Clamp the pipe clamp tightly

7. The main switch shall be firstly opened. The middle valve of the three valves manifold shall be shut. (the new joint shall be checked for leakage through adopting suds)

8. The watch needle of differential pressure gauge shall be set to zero in two min. (if the watch needle is slightly fluctuated on the zero setting, the resetting is not of necessity)

Note: While installing the gauge or disassembling the gauge, the middle valve, P+ and P- valves shall be completely opened as to guarantee the normal application of the instrument.

YCA系列选型双膜片高静压差压表选型

YCA series selection for double-diaphragm high static pressure differential pressure gauge

双膜片高静压差压表YCA Double-diaphragm high static pressure differential pressure gauge YCA							
压力表类型 Types of pressure gauge		无代码 No Coding					
普通型 Ordinary type		N					
隔膜螺纹 Diaphragm thread							
连接符号 Connection symbol		-					
表盘直径 Diameter of the gauge disc				φ100			
φ100				φ150			
规格 Specification					H		
防腐性 Corrosion-proof							
标性型 Normalized					无代码 No Coding		
安装方式 Installation method						TH	
后背板安装 Installation of rear panel						GH	
管卡安装 Installation of pipe clamp							
精度等级 Precision grade							
1.6 Grade							1.6
2.5 Grade							2.5
连接螺纹 Connecting thread							
M20×1.5							M20×1.5
G1/2							G1/2
NPT1/2							NPT1/2
其他 Others							其他 Others

化学密封

Chemical seal

产品简介

隔膜系列压力表是由一个不同类型的标准压力表与一个隔膜隔离体配接而成的。隔膜隔离体中配有隔膜，可以将被测介质与填充液分开，增加了标准型压力表对特殊腐蚀性要求、温度高、粘度大或含有固态悬浮物、易结晶介质的测量性能。主要应用在石油化工、制碱、化纤、制药、钢铁、食品等行业。隔膜隔离体分为螺纹连接和法兰连接。

结构原理

隔膜膜片在被测介质压力 P 的作用下产生变形，使内部填充液形成一个相当于 P 的压力 P' 经工作液的传导，使压力仪表中的弹簧管发生变形，并在与之相配接的压力仪表上显示出被测的压力值。

Product introduction

The diaphragm pressure gauge is made of a different type of standard gauge and a diaphragm spacer. The diaphragm body is equipped with diaphragm which can isolate the the measured medium and the filling liquid so as to increase the performance of corrosion of the standard type pressure gauge. The material with high temperature, the high viscosity or containing solid floating matters, material which is easy to form crystal. It is mainly used in petrochemical, alkali, chemical fiber, pharmaceutical, iron and steel, food and other industries. Diaphragm separator is divided into screw connection and flange connection.

Structure principle

Diaphragm deformation is generated under the action of P which is actually the measured media so that the internal filling solution form a pressure P' equivalent to the P . Through the conduction of the working liquid, the spring in the pressure gauge will form deformation and the measured pressure value is displayed in the pressure gauge matched.

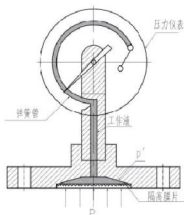

隔膜压力表密封液的液位差

隔膜膜片在被测介质压力 P 的作用下产生变形，使内部填充液形成一个相当于 P 的压力 P' 经工作液的传导，使压力仪表中的弹簧管发生变形，并在与之相配接的压力仪表上显示出被测的压力值。

Liquid level difference of sealing liquid of diaphragm pressure gauge

Diaphragm deformation is generated under the action of P which is actually the measured media so that the internal filling solution form a pressure P' equivalent to the P . Through the conduction of the working liquid, the spring in the pressure gauge will form deformation and the measured pressure value is displayed in the pressure gauge matched.

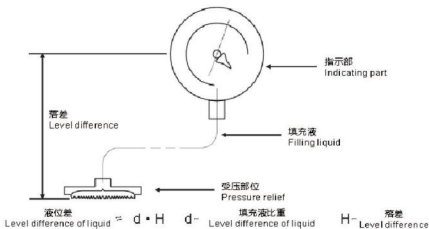



标度范围、精确度等级

Scale range and accuracy class

型号 Model	名称 Name	图样 Photo sample	应用 Application
F01	平波膜片 Flush diaphragm		有高温要求的过程和石化行业 The process and petrochemical industry the with high temperature requirements
F02	夹心型 Sandwich-type		有高温要求的过程和石化行业 The process and petrochemical industry the with high temperature requirements
F03	带可插入扩展膜片的 法兰隔膜密封 Flange diaphragm seal with insert expansion diaphragm		带可插入扩展膜片的法兰隔膜密封 Flange diaphragm seal with insert expansion diaphragm
F04	内嵌膜片 Embedded diaphragm		有高温要求的过程和石化行业 The process and petrochemical industry the with high temperature requirements
F05	带可插入扩展膜片的夹心型 Sandwich type with insert expansion membrane		过程和石化行业，尤其适用于厚壁 或隔离的容器和管道 The process and petrochemical industries, especially suitable for thick walled vessels and piping or quarantine
F06	整体焊接式或鞍型法兰 Integral welding type or saddle flange		用于在化学工程和石化行业中连接整体 焊接式法兰或鞍型法兰 Used in chemical engineering and petrochemical industry to connect the whole welding type flange or saddle flange
F07	纸浆和造纸工业 Pulp and paper industry		适用于纸浆和造纸工业 Suitable for pulp and paper industry
F08	圆筒型隔膜密封，夹心型 Sealed cylindrical sandwich diaphragm		可直接、永久性安装到管线；适用于流动 介质；或用于无死区测量点 It can be installed directly into the pipeline; applicable to the mobile media; or for non-dead area measurement points
F09	圆筒型隔膜密封，夹心型 Sealed cylindrical sandwich diaphragm		可直接、永久性安装到管线；适用于流动 介质；或用于无死区测量点 It can be installed directly into the pipeline; applicable to the mobile media; or for non-dead area measurement points





螺纹式隔离密封

Isolation seal of screw type

型号 Model	名称 Name	图样 Photo sample	应用 Application
F01	小型隔离密封, 带平嵌隔离 Small isolated seal with flat block		过程和石化行业, 尤其适用于厚壁或隔离的容器和管道 The process and petrochemical industries, especially suitable for thick walled vessels and piping or quarantine
F02	焊接结构 Welded structure		用于在化学工程和石化行业中连接整体焊接式法兰或鞍型法兰 Used in chemical engineering and petrochemical industry to connect the whole welding type flange or saddle flange
F03	焊接结构, 经济型 Welded structure, economical type		适用于纸浆和造纸工业 Suitable for pulp and paper industry
F04	大盘膜片, 螺纹连接设计 Large diaphragm, threaded connection design		可直接、永久性安装到管线; 适用于流动介质; 或用于无死区测量点 It can be installed directly into the pipeline; applicable to the mobile media; or for non-dead area measurement points
F05	舌型隔膜密封 Tongue diaphragm seal		可直接、永久性安装到管线; 适用于流动介质; 或用于无死区测量点 It can be installed directly into the pipeline; applicable to the mobile media; or for non-dead area measurement points

卫生连接型隔膜密封

Diaphragm seal of the sanitary connection type

型号 Model	名称 Name	图样 Photo sample
WF01	DRD连接 DRD connection	
Wf02	外螺纹接头 External thread joint	
Wf03	卡箍型 Clamp type	
Wf04	圆筒型隔膜密封 Cylindrical diaphragm seal	
Wf05	圆筒型隔膜密封, 无菌连接 Cylindrical diaphragm seal, sterile connection	

附件

Accessory

阻尼器 Damper

用来御防强烈的流体脉冲，以保护压力表不受损坏的装置。适用于被测介质有强烈脉冲的压力系统中。

It is used to resist a strong flow of fluid to protect the pressure gauge from damage. The pressure system is suitable for the pressure system of the medium with strong impulse.

结构

The structural diagram of the damper is shown in the following content:

F	h	N
M20×1.5a-M20×1.5b	20	24
1/2"NPT a-1/2"NPT b	20	24
G1/2" a-G1/2" b	20	24

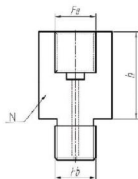

散热器 Radiator

主要用于冷却被测高温气体液体等压力介质，能有效降低压力介质的温度，并可减少压力介质的压力脉动对压力表的冲击，使压力表能长期、准确的测量高压介质，常用于不饱和蒸汽等高温介质的测量。

It is mainly used for cooling the high temperature gas and liquid whose pressure is measured it can effectively reduce the pressure of the medium temperature and the impact the pressure impulse of the pressure medium on the pressure gauge to make the pressure gauge be able to measure high pressure medium for a long time, accurately it is commonly used in the measurement of unsaturated steam and other high temperature medium.

结构

The structural diagram of the damper is shown in the following content:

F	h	N
M20×1.5a-M20×1.5b	50	75
1/2"NPT a-1/2"NPT b	50	75
G1/2" a-G1/2" b	50	75

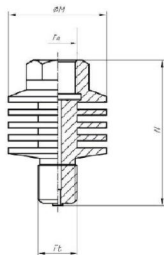

过压保护器 Overvoltage protection device

用来御防强烈的流体脉冲，以保护压力表不受损坏的装置。适用于被测介质有强烈脉冲的压力系统中。

It is used to resist a strong flow of fluid to protect the pressure gauge from damage. The pressure system is suitable for the pressure system of the medium with strong impulse.

外形尺寸

Dimension

F	D	h	M	N
M20×1.5a-M20×1.5b	44	80	110	37
1/2"NPT a-1/2"NPT b	44	80	110	37

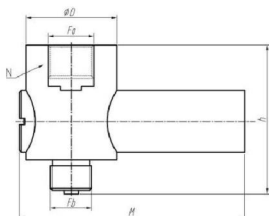

冷凝管 Condenser tube

冷凝管主要应用在具渗透或饱和的蒸气高温环境之下，避免压力表内部直接与高温流体接触。

The condenser tube is mainly used in the high temperature environment with infiltration or saturation to avoid direct contact with high temperature fluid in the pressure gauge.



外形尺寸

Dimension

d1	d2	M	N	D×f
M20×1.5	M20×1.5	20	20	-
G1/2	G1/2	20	20	$\phi 14 \times 2$
NPT1/2	NPT1/2	20	20	-

最大允许工作压力：20Mpa

最大允许耐压：30Mpa

Maximum allowable working pressure: 20Mpa

Maximum allowable voltage: 30Mpa

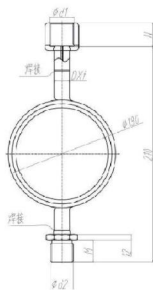



地址(ADD): 安徽省天长市仁和南路20号
NO.20 South Renhe Road,Tianchang City,Anhui Province
邮编(ZIP): 239300
电话(TEL): 86-0550-7777777 7038698 7308802
传真(FAX): 86-0550-7028077 7038699
网址(HTTP): www.tiankang.com
邮箱(E-mail): xsc@tiankang.com